



THE EXHIBITORS'™
HAND
BOOK
MODULAR DISPLAY SOLUTIONS



1 | BANNER STANDS | RETRACTABLE



9 | BANNER STANDS | TELESCOPIC



11 | BANNER STANDS | SPRING BACK



14 | BANNER STANDS | AERO



15 | OUTDOOR DISPLAYS



21 | HOPUP™ TENSION FABRIC DISPLAYS



25 | COYOTE™ POPUP DISPLAY SYSTEMS

SYMBOLS USED IN THE EXHIBITORS' HANDBOOK™:



product made in the U.S.



economy product



premium product



product can be recycled
(does not include graphic application)



product comes with a carry bag or case



standard product

FORMULATE™ TENSION FABRIC SYSTEMS | 30



TABLE THROWS & RUNNERS | 73



ORBITAL EXPRESS™ TRUSS | 77



LINEAR™ EXTRUSION DISPLAY SYSTEMS | 93



VECTOR FRAME™ FABRIC DISPLAYS | 99



FOLDING DISPLAY PANELS | 103



ACCENTS & ACCESSORIES | 108



WARRANTY KEY FOR THE EXHIBITORS' HANDBOOK™:



lifetime warranty (hardware)



5 year warranty (hardware)



1 year warranty (hardware)



90 day warranty (hardware)



graphics limited 1 year warranty (indoor products)



graphics limited 6 month warranty (outdoor and table throw products)



FAST.CLEAR.COMMUNICATION. **BANNER STANDS**

Largest selection of banner stand choices and options • Premium, mid-range and economy stands • Retractable, Telescopic and Spring Back options • Great quality • High-end functionality, features and durability • Specifically designed with unique styling points, giving an exceptional appearance • Multiple accessory and light options



BLADE LITE

23.5" WIDE BLD-LT-600

36" WIDE BLD-LT-920

47.25" WIDE BLD-LT-1200

59" WIDE BLD-LT-1500

- standard height = 83.25"
- four widths to choose from: 23.5", 36", 47.25", 59"
- premium top rail
- weighted base for stability
- adjustable leveling feet
- 3-piece bungee pole



PREMIUM RETRACTABLE BANNER STANDS



Premium Retractable banner stands provide superior, high-end functionality, features and durability, as well as unique styling points for exceptional appearance. Premium banners include a protective, molded carry bag and feature a lifetime hardware warranty.

BANNER STANDS | RETRACTABLE

PREMIUM

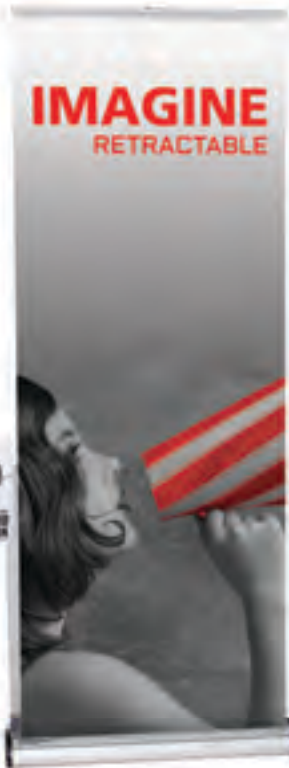

IMAGINE

31.5" WIDE IMG-800-S

- variable graphic height = 29.5" - 83.35"
- graphic tensioner
- integrated pole storage
- interchangeable graphic cassette
- adjustable feet on base
- telescopic pole
- shown with optional literature pocket accessory (AKIT-1L)



BARRACUDA

31.5" WIDE silver: BCD-800-S
black: BCD-800-B

- variable graphic height = 29.5 83.35"
- anodized silver or black base options
- graphic tensioner
- integrated pole storage
- adjustable feet on base
- telescopic pole
- shown with optional literature pocket and tabletop (AKIT-1S1L)



ADVANCE

31.5" WIDE ADV-800-S

- variable graphic height = 29.5" - 83.35"
- double sided
- graphic tensioner
- integrated pole storage
- interchangeable graphic cassette
- adjustable feet on base
- telescopic pole
- shown with optional light Lumina 2 (LUM-2-1)



EXCALIBUR

31.5" WIDE silver: EXC-800-S
black: EXC-800-B

- variable graphic height = 29.5" - 83.35"
- double sided
- anodized silver or black base options
- graphic tensioner
- integrated pole storage
- adjustable feet on base
- telescopic pole
- shown with optional tabletop accessory (AKIT-1S)





STANDARD RETRACTABLE BANNER STANDS

Standard Retractable banner stands incorporate customary features designed to provide everyday reliability, durability and ease of use. Standard banners include a mid-range canvas carry bag and typically feature a five-year to lifetime hardware warranty.



ORIENT 1

31.5" WIDE silver: ONT-800-S-3
black: ONT-800-B-3

35.5" WIDE silver: ONT-920-S-3
black: ONT-920-B-3

39.25" WIDE silver: ONT-1000-S-3
black: ONT-1000-B-3

- standard graphic height = 83.25"
- anodized silver or black base options
- molded end caps
- adjustable feet on base
- 3-piece bungee pole

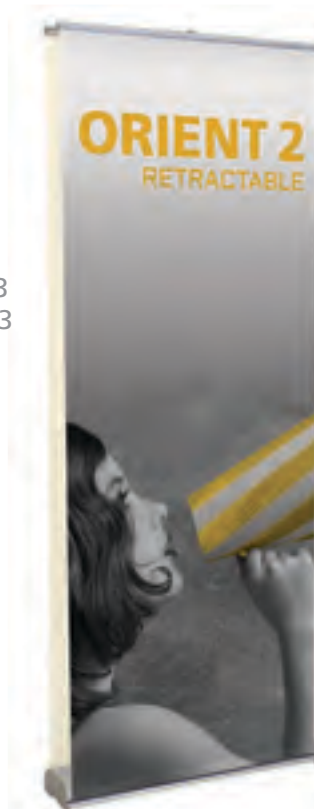

ORIENT 2

31.5" WIDE silver: ONT-800-DBL-S-3
black: ONT-800-DBL-B-3

35.5" WIDE silver: ONT-920-DBL-S-3
black: ONT-920-DBL-B-3

39.25" WIDE silver: ONT-1000-DBL-S-3
black: ONT-1000-DBL-B-3

- standard graphic height = 83.25"
- double-sided
- anodized silver or black base options
- molded end caps
- adjustable feet on base
- 3-piece bungee pole



PACIFIC

31.5" WIDE PAC-800-S-2

35.5" WIDE PAC-920-S-2

39.25" WIDE PAC-1000-S-2

- standard graphic height = 83.75"
- anodized silver base
- molded end caps
- swivel-out foot
- 3-piece bungee pole



CONTENDER

23.5" WIDE silver: CN-24-S
black: CN-24-B

29.5" WIDE silver: CN-30-S
black: CN-30-B

35.5" WIDE silver: CN-36-S
black: CN-36-B

47.5" WIDE black: CN-48-B

- standard graphic height = 77.5"
- swivel-out foot
- silver or black base options
- laser cut steel ends & swaged pole



STANDARD RETRACTABLE BANNER STANDS



Standard Retractable banner stands incorporate customary features designed to provide everyday reliability, durability and ease of use. Standard banners include a mid-range canvas carry bag and typically feature a five-year to lifetime hardware warranty.



ELEVATE

33.25" WIDE ELEVATE

- over 8' tall
- variable graphic height = 37.75" - 95.25"
- roller access via flip-top lid and removable self-locking graphic roller
- black aluminum body with chrome end caps
- telescopic pole (4 segments)

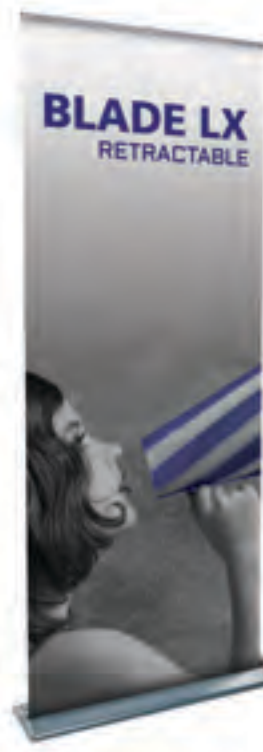

BLADE LX

33.5" WIDE BLD-LX-GRY

- standard graphic height = 83.25"
- anodized gunmetal base
- removable self-locking graphic roller
- graphic slider
- adjustable feet on base
- premium top rail
- 3-piece bungee pole



ORCHID

33.5" WIDE ORCHID

- standard graphic height = 76.75"
- quick to assemble and easy to use
- bamboo base, rail and pole are a sustainable & eco-friendly choice
- slide graphic rail
- 3-piece pole



BLOK

33.5" WIDE BLOK-850

- standard graphic height = 79.25"
- black base with chrome end caps
- 3-piece bungee pole





ECONOMY RETRACTABLE BANNER STANDS

Economy Retractable banner stands incorporate basic design features, functionality and reliability. Economy banners include a basic carry bag and feature a 90-day hardware warranty.



START

31.25" WIDE STRT-800

- standard graphic height = 79.25"
- snap top graphic rail
- swivel foot
- anodized silver base
- 3-piece bungee pole



FREEDOM

31.5" WIDE FRDM-800

39.25" WIDE FRDM-1000

- standard graphic height = 79.25"
- snap top graphic rail
- 3-piece bungee pole



RETRACTOR 4

32.75" WIDE RTRC-4

- standard graphic height = 78.25"
- double sided
- snap top graphic rail
- 3-piece bungee pole



RETRACTOR 5

36" WIDE RTRC-5

- standard graphic height = 79.375"
- velcro graphic application
- snap top graphic rail
- 3-piece bungee pole



ECONOMY RETRACTABLE BANNER STANDS

Economy Retractable banner stands incorporate basic design features, functionality and reliability. Economy banners include a basic carry bag and feature a 90-day hardware warranty.



BANNER STANDS | RETRACTABLE

ECONOMY



shown at maximum and minimum heights

GIANT MOSQUITO

NEW

35.5" WIDE MSQT-GIANT-920-S

- variable graphic height = 68" - 122"
- anodized silver base
- swivel-out foot
- snap top graphic rail
- adjustable telescopic pole
- heavy duty, weighted stand



MSQT-1500

MSQT-1200

MSQT-800-S

MOSQUITO

31.5" WIDE silver: MSQT-800-S
black: MSQT-800-B

47.25" WIDE silver: MSQT-1200

59" WIDE silver: MSQT-1500

- standard graphic height = 78.5"
- anodized silver or black base options (800mm only)
- swivel-out foot & snap top graphic rail
- 800mm unit is supplied with one bungee pole per unit, 1200mm and 1500mm come with two bungee poles per unit





ECONOMY RETRACTABLE BANNER STANDS

Economy Retractable banner stands incorporate basic design features, functionality and reliability. Economy banners include a basic carry bag and feature a 90-day hardware warranty.

QUICKWALL

31.5" WIDE silver: QWK-S
black: QWK-B

- standard graphic height = 78.5"
- unit width: 32"
- graphic width: 31.5"
- anodized silver or black base options
- kit includes 3 Mosquito 800 banner stands and 1 OCB banner stand case
- snap top graphic rail



QUICKSTAND

31.5" WIDE silver: QWK-STND-S
black: QWK-STND-B



- standard graphic height = 78.5"
- anodized silver or black base options
- kit includes 1 Mosquito 800 banner stand, 1 OCB banner stand case, and 1 Lumina 12-C banner stand light
- swivel-out foot
- snap top graphic rail
- 3-piece bungee pole



STANDARD TELESCOPIC BANNER STANDS



Standard Telescopic banner stands incorporate customary features designed to provide everyday reliability, durability and ease of use. Standard banners include a mid-range canvas carry bag and typically feature a one-year hardware warranty.

PEGASUS MINI

27.5" - 48" WIDE silver: PGSUS-MIN-S
black: PGSUS-MIN-B

PEGASUS

52.5" - 95" WIDE silver: PGSUS-S
black: PGSUS-B

- variable graphic height = 36" - 96"
- single or double-sided graphics
- allows for custom size graphics
- easy to store
- steel feet for stability
- telescopic pole for adjustable graphic width and height



BANNER STANDS | TELESCOPIC

STANDARD



DASH

31.5" WIDE single sided: DSH-M-1
double sided: DSH-M-2

- variable graphic height = 31.5" - 78.5"
- stable, anodized aluminum
- quick & easy to erect



DASH MEGA

36" WIDE single sided: DSH-ME
double sided: DSH-ME-2

- variable graphic height = 36" - 93.5"
- stable, anodized aluminum
- quick & easy to erect





STANDARD TELESCOPIC BANNER STANDS

Standard Telescopic banner stands incorporate customary features designed to provide everyday reliability, durability and ease of use. Standard banners include a mid-range canvas carry bag and typically feature a one-year hardware warranty.



DASH LITERATURE POCKET

31.5" WIDE DSH-M-LR

- recommended graphic height = 44"
- 3 pocket literature dispenser option to attach to a Dash unit



UNO

31.5" WIDE UN-1-ST

35.5" WIDE UN-1-MG

48" WIDE UN-1-MO

- variable graphic height = 35" - 85.5"
- powder coated black weighted base

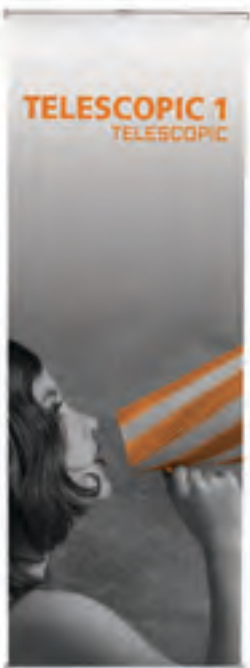

TELESCOPIC 1

23.5" WIDE TEL-1-A

- variable graphic height = 36" - 70"
- single or double sided



TELESCOPIC 4

31" WIDE TEL-4

- standard graphic height = 77"
- telescopic pole



STANDARD SPRING BACK BANNER STANDS

Standard Spring Back banner stands incorporate customary features designed to provide everyday reliability, durability and ease of use. Standard banners include a mid-range canvas carry bag and typically feature a one-year hardware warranty.

LIGHTNING

31" WIDE LTNG

- standard graphic height = 77"
- snap-lock graphic rails
- 3-piece bungee pole



ECONOMY SPRING BACK BANNER STANDS

Economy Spring Back banner stands incorporate basic design features, functionality and reliability. Economy banners include a basic carry bag and feature a 90-day hardware warranty.



SPRING 1-1

23.5" WIDE SB-1-1

- graphic height = 59" or 78"



SPRING 1-2

26.5" WIDE SB-1-2

- graphic height = 59" or 78"

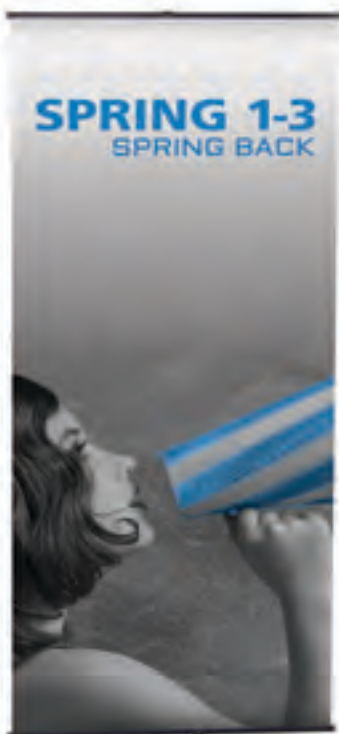

SPRING 1-3

35.125" WIDE SB-1-3

- graphic height = 59" or 78"



SPRING 3

27.5" WIDE SB-3

- standard graphic height = 70.75"
 - #3 grommets in corners
 - single or double sided



ECONOMY SPRING BACK BANNER STANDS



Economy Spring Back banner stands incorporate basic design features, functionality and reliability. Economy banners include a basic carry bag and feature a 90-day hardware warranty.

BANNER STANDS | SPRING BACK

ECONOMY



SPRING 4

27" WIDE SB-4

- standard graphic height = 62.25"
- #3 grommets in corners



SPRING 6

24.5" WIDE SB-6

- standard graphic height = 63"
- #3 grommets in corners



SPRING 7

29.5" WIDE SB-7

- variable graphic height = 61.5" - 69"
- #3 grommets in corners



SCROLLER

28.75" WIDE SC-1

- variable graphic height = 48" - 72"
- top scrolling mechanism allows for a variety of lengths and styles
- utilizes standard 110v power

AERO



- indoor modular display system
- adjustable heights & angles
- shown with optional Lumina 200 floodlights
- available "à la carte" to create more combinations

Aero Basic Kit:

AERO-1200-BASIC

- comes with 3 1200mm cassettes and 4 uprights with base

Aero Complete Kit:

AERO-1200-KIT

- comes with 3 1200mm cassettes in an OCH2 case and 2 120 watt lights, no graphics (must ship freight)



complete kit comes as shown above



configurations above shown with additional panels and lights



CAPTURE.YOUR.ATTENTION. OUTDOOR DISPLAYS

One-stop-shop for all your outdoor signage needs • The Zoom™ line of outdoor flags span heights of 8' to over 16' • Great for outdoor sporting events and arenas, concerts, festivals or to draw attention to any storefront • Strong, solid, stable, wind-resistant, durable • Graphics are long-lasting and can endure exposure to outdoor elements

ZOOM™ TENT

hardware only kit: TNT-3MX3M-FRM-HEX
kit with canopy: TNT-3MX3M-HEX-(COLOR)
canopy only: TNT-CAN-(COLOR)
full wall kits: TNT-FLL-WLL-K-(COLOR)
half wall kits: TNT-HLF-WLL-(COLOR)



- opens to base size of 9.6' x 9.6'; coverage area shades 5 people comfortably
- rust-resistant aluminum extrusion frame is completely self-contained with no loose parts
- canopy offered in 5 standard colors (black, blue, grey, white and red) with press logos and/or vinyl lettering; can also be custom printed
- polyester canopies and sidewalls are water and UV-resistant, providing the ultimate protection from the sun
- hardware only kit includes frame, stakes, guy lines and rolling carrying bag
- canopy kits include canopy (standard colors or custom printed), hardware frame, stakes, guy lines and rolling carrying bag
- sidewalls and rail skirts offered in standard colors and custom prints; sold separately
- folds compactly into portable, rolling carry bag
- optional hard shell OCE expandable case available as an upgrade

comes with
easy compact
roller bag



OUTDOOR DISPLAYS

digitally printed
canopies,
sidewalls
and backwalls
available



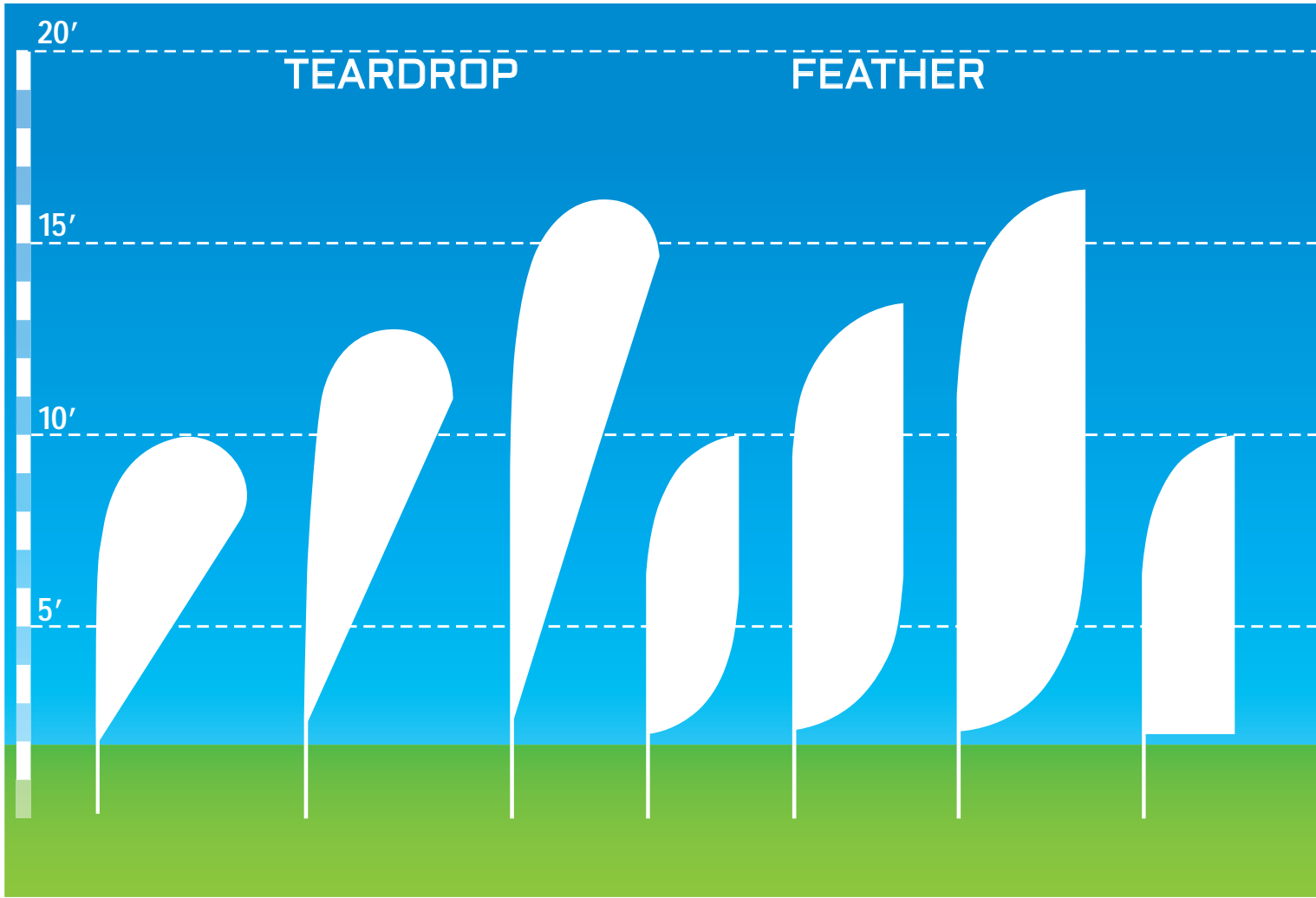

ZOOM™ FLAGS

- can be used indoors or out
- graphic rotates in wind
- water fillable donut adds stability to quad leg (optional upgrade)
- graphic printed on flag material
- double sided graphic available
- floor base & ground stake included



shown with optional upgrade donut water fillable base



ZOOM™ BASE OPTIONS



ground stake (included)



auger base (ZOOM-AUG)



drive-over base (ZOOM-VEHICLE)



All Outdoor products have a one year hardware warranty and are eco-friendly.

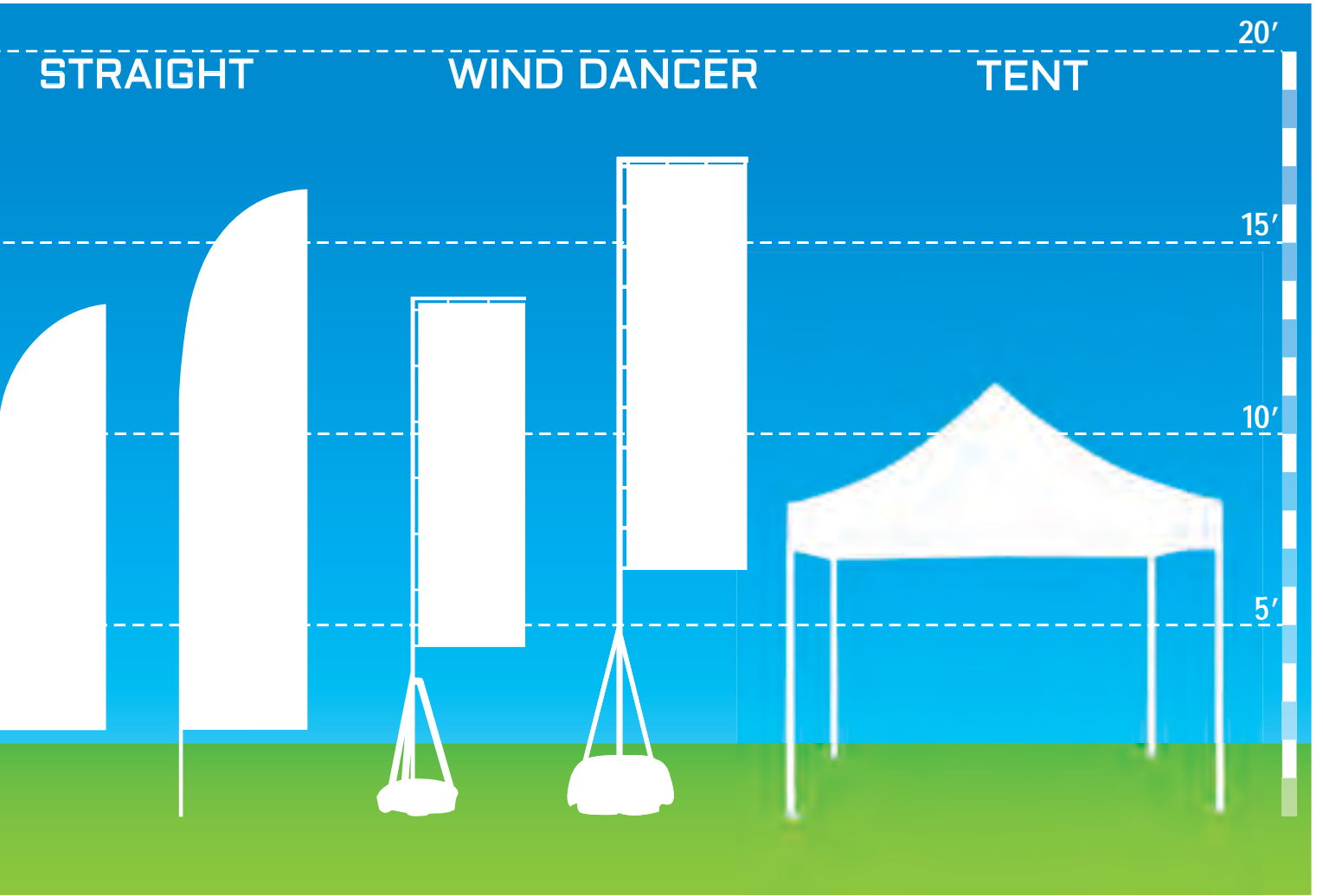

WIND DANCER LT
WIND-LT

- adjustable graphic height = up to 13'6"
- hollow base can be filled with either water or sand as weighing agent
- optional carry bag available



WIND DANCER
WIND-MX

- adjustable graphic height = up to 17'3"
- flag is approximately 43" wide
- hollow base can be filled with either water or sand as weighing agent
- optional carry bag available



All Outdoor products have a one year hardware warranty and are eco-friendly.

OUTDOOR SIGNAGE

Outdoor signage, flags and displays are great for outdoor sporting events and arenas, concerts, festivals or to draw attention to any storefront. Outdoor display products are strong, solid, stable, wind-resistant and durable. Graphics are long-lasting and can endure exposure to outdoor elements.



SPINNAKER

SPKR

- single or double sided
- portable outdoor billboard
- maximum graphic area of 8'w x 8'h (weather & wind conditions permitting)
- 8'7" tall
- easy grommet graphic attachment
- optional carry bag available



MONSOON

MONSN-2

- visual graphic area = approx. 92.125" w x 32" h
- semi-portable single or double sided billboard
- easy grommet graphic attachment
- includes ground stakes & bungee rope



SPRING 5

SB-5

- standard graphic height = 70.75"
- 31.5" wide
- indoor or outdoor use
- single or double sided
- hollow base can be filled with either water or sand as weighing agent
- easy grommet graphic attachment
- tension pole system



BLIZZARD

BLZD

- max width x min height: 40" w x 49.5" h
- min width x max height: 23.5" w x 80" h
- max width x max height: 40" w x 74.5" h
- min width x min height: 23.5" w x 49.5" h
- outdoor banner stand
- hollow base can be filled with either water or sand as weighing agent
- easy grommet graphic attachment





OUTDOOR SIGNAGE

Outdoor signage, flags and displays are great for outdoor sporting events and arenas, concerts, festivals or to draw attention to any storefront. Outdoor display products are strong, solid, stable, wind-resistant and durable. Graphics are long-lasting and can endure exposure to outdoor elements.

PARKWAY

single span: PKWY-S-SPN-3
double span: PKWY-D-SPN-3

- single span = 32"l x 60"h
- double span = 67"l x 60"h
- withstands winds up to 38MPH
- single or double span street pole banner



ROCKET RCKT

- single or double sided
- visual graphic area = 24"w x 36"h
- 3 legs can be filled with water or sand
- spring-loaded graphic support
- 1/8" coroplast plastic or similar substrate recommended
- ideal for contour cut custom graphics
- graphic size may vary



BRUTE BRUTE

- use one to hold a smaller graphic, or as many as you need to hold a large graphic
- secure grip allows for use outdoors in the elements as well as inside
- quick set-up, easy storage
- fill with water or sand, must empty 100% after use



contoured base sits stable on uneven terrain

recommended width:
1 Brute per 4' of signage

WHIRLWIND WHRL-WND-1

- 31.1"w x 45.7"h x 19.7"d
- front-loading snap frames constructed from aluminum & powder-coated steel
- single or double sided
- includes clear lens cover
- dual-spring design flexes to withstand wind gusts
- compact durable base can be filled with water or sand for extra stability
- integrated wheel set





FAST.DYNAMIC.FABRIC. HOPUP™ TENSION FABRIC

Combining style and speed, the intergrated fabric graphic makes the Hopup™ the fastest display on the market • The Hopup is one of the most dynamic and popular large format graphic displays due to its maximum impact with minimal effort • Lightweight and highly portable • Easy to set up and packs away as fast as it sets up



HOPUP™ BACKWALLS

The Hopup™ is one of the most dynamic and popular large format graphic displays due to its maximum impact with minimal effort. Hopup Tension Fabric Displays come in a variety of sizes and are offered in straight and curved frames. Hopups are lightweight and highly portable and they pack away as easy as they set up! Lighting kits make the Hopup glow and stand out even more.

HOPUP | TENSION FABRIC



BACKLIT HOPUP™

- lightweight, heavy duty silver frame
- supports an integrated full fitted fabric graphic mural with end caps only
- available in 5', 7½' or 10' sizes (curved only)
- LED lights include one year limited warranty
- comes in an OCP molded case



interior lights are attached with velcro to back fabric panel

STRAIGHT HOPUP™ CONFIGURATIONS



2½' tabletop
footprint dimensions:
31" w x 31" h x 12" d
HOP-1X1FG-S



5' tabletop
footprint dimensions:
60.06" w x 31" h x 12" d
HOP-2X1FG-S



5' tabletop
footprint dimensions:
60.06" w x 60.06" h x 12" d
HOP-2X2FG-S



7½' tabletop
footprint dimensions:
89.13" w x 60.06" h x 12" d
HOP-3X2FG-S



2½' full height standard display
footprint dimensions:
31" w x 89.13" h x 12" d
HOP-1X3FG-S



5' full height standard display
footprint dimensions:
60.06" w x 89.13" h x 12" d
HOP-2X3FG-S



7½' full height standard display
footprint dimensions:
89.13" w x 89.13" h x 12" d
HOP-3X3FG-S



10' full height standard display
footprint dimensions:
118.19" w x 89.13" h x 12" d
HOP-4X3FG-S



11½' full height standard display
footprint dimensions:
139" w x 89.13" h x 12" d
HOP-5X3FG-S

HOPUP™ COUNTER HOP-CT-S

- collapsible display counter
- includes black internal shelf
- hinged top available in all four laminate finishes (page 98)



All Hopup frames are eco-friendly, come with a rolling carry case, and have a lifetime warranty.

CURVED HOPUP™ CONFIGURATIONS



5' tabletop
footprint dimensions:
63.5" w x 31" h x 18.5" d
HOP-2X1FG-C



5' tabletop
footprint dimensions:
63.5" w x 60.06" h x 18.5" d
HOP-2X2FG-C



7½' tabletop
footprint dimensions:
91" w x 60.13" h x 23.25" d
HOP-3X2FG-C



5' full height standard display
footprint dimensions:
63.5" w x 89.13" h x 18.5" d
HOP-2X3FG-C



7½' full height standard display
footprint dimensions:
91" w x 89.13" h x 23.25" d
HOP-3X3FG-C



10' full height standard display
footprint dimensions:
115" w x 89.13" h x 33.5" d
HOP-4X3FG-C



11½' full height standard display
footprint dimensions:
139" w x 89.13" h x 47" d
HOP-5X3FG-C



fits in an OCP
wheeled molded
storage case
(page 119)

all size configurations available
with or without endcaps



All Hopup frames are eco-friendly, come with a rolling carry case, and have a lifetime warranty.



RELIABLE.PORTABLE.ESSENTIAL. **POPOP DISPLAY SYSTEMS**

The Coyote™ popup display system combines reliability, portability and style • State-of-the-art rare earth neo magnets on individual channel bars make Coyotes fast and easy to popup and breakdown, especially when compared to complicated “snap in” channel bars and fragile locking style systems • All Coyote displays are offered in curved or straight systems, single or double sided • Option of combining either captivating graphic mural panels or versatile Velcro-friendly fabric panels



COYOTE™ POPUP DISPLAY SYSTEMS

This fully magnetic popup display system provides a graphic or velcro receptive fabric backwall. Coyote™ popup displays are portable, versatile, durable and easy. The Coyote line features a plethora of accessory options to add such as shelves, monitor mounts and case-to-counter conversion kits and graphics.

POPOP DISPLAY SYSTEMS



FABRIC CHOICES

All Coyote popup display systems are available with printed graphic murals or "velcro-friendly" fabric panels of your choice. Actual fabric color may vary slightly.

regal - smooth exhibit & display fabric

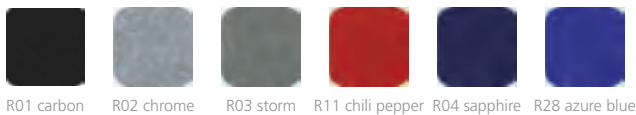

premier - ribbed exhibit & display fabric





4' tabletop
footprint dimensions:
45.5" w x 30.63" h x 12.5" d
COY-KKG-1X1-C



6' tabletop
footprint dimensions:
73" w x 30.63" h x 19.25" d
COY-KKG-2X1-C



6' tabletop
footprint dimensions:
73" w x 59.38" h x 19.25" d
COY-KKG-2X2-C



8' tabletop
footprint dimensions:
97.25" w x 59.38" h x 25" d
COY-KKG-3X2-C



6' full height
slim-line display system
footprint dimensions:
69.3" w x 87.56" h x 19.25" d
COY-KKG-2X3-C



8' full height
standard display system
footprint dimensions:
97.25" w x 87.56" h x 25" d
COY-KKG-3X3-C



10' full height
standard display system
footprint dimensions:
118" w x 87.56" h x 36.5" d
COY-KKG-4X3-C



8' serpentine
full height display system
footprint dimensions:
97.86" w x 87.56" h x 19.5" d
COY-KKG-ST-8



10' serpentine
full height display system
footprint dimensions:
129.5" w x 87.56" h x 19.5" d
COY-KKG-ST-10



10' standard horseshoe
full exhibit system
footprint dimensions:
125.2" w x 87.56" h x 54.3" d
COY-KKG-HS



20' deluxe horseshoe
full exhibit system
footprint dimensions:
193.5" w x 87.56" h x 59.5" d
COY-KKG-DHS



20' gullwing full trade show
exhibit system
footprint dimensions:
231" w x 87.56" h x 41" d
COY-KKG-GW



20' serpentine full trade show
exhibit system
footprint dimensions:
217.75" w x 87.56" h x 60.5" d
COY-KKG-20



All Coyotes come with a lifetime hardware warranty.
Kits shown come with lights featured.

OCP CASE TO COUNTER CONVERSION



OCP

- **NEW** premium latches for maximum strength
- blow molded transit case
- built in wheels, handle
- light storage in the lid



Roll Wrap: OCP-C2C-G

- available in fabric or graphic
- converts OCP to a counter
- polymer counter surface exposed



Stretch Wrap: OCP-SW-G

- stretch fabric pullover
- converts OCP to a counter
- polymer counter surface covered by fabric

OCP2 CASE TO COUNTER CONVERSION

NEW



OCP2

- **NEW** premium latches for maximum strength
- hinged lid with internal light storage
- robust, roto-molded plastic



Roll Wrap: OCP2-C2C-G

- available in fabric or graphic
- converts OCP2 to a counter
- polymer counter surface exposed



Stretch Wrap: OCP2-SW-G

- stretch fabric pullover
- converts OCP2 to a counter
- counter surface covered by fabric

OCP ELITE CASE TO COUNTER CONVERSION



OCP-ELITE

- heavy duty shipping and storage case
- lid can be used as a step stool
- access door provides storage when unit is used as a counter
- UPS approved



Roll Wrap: ELITE-C2C-G

- available in fabric or graphic
- converts OCP Elite to a counter
- counter surface exposed



Stretch Wrap: ELITE-SW-G

- stretch fabric pullover
- converts OCP Elite to a counter
- counter surface covered by fabric



All molded cases have a one year hardware warranty and are an eco-friendly choice.

COYOTE™ MINI

- approx. 20% smaller than standard Coyote™ tabletops
- entire display rolls up into special storage sleeve which slides into a padded carry case
- kit includes frame, channel bars, panel hangers, carry case, & 2 lights
- add an optional OCS hard case for shipping or extra secure storage

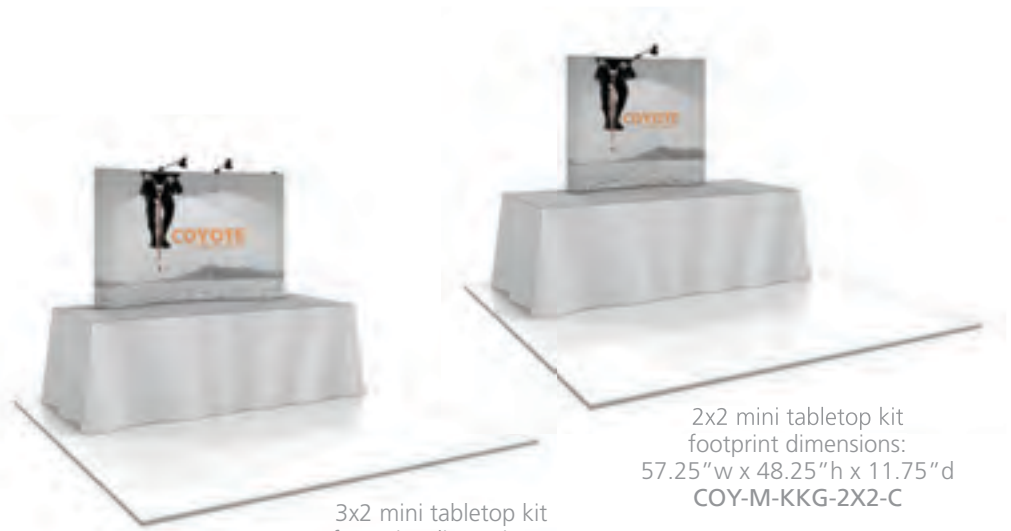

3x2 mini tabletop kit
footprint dimensions:
77.5" w x 48.25" h x 16.25" d
COY-M-KKG-3X2-C

2x2 mini tabletop kit
footprint dimensions:
57.25" w x 48.25" h x 11.75" d
COY-M-KKG-2X2-C



easy rollup carry bag holds Coyote™ Mini hardware and graphics

BUBBLE PANEL

COY-K-GBBP-O

- forward facing, convex panel
- panel can be fabric, opaque graphic or rear illuminated graphic (light kit sold separately)
- hardware can be stored with display in OCP



MONITOR MOUNT

COY-MM

- fully integrates with straight or curved Coyote™ systems
- one panel cut to fit the monitor
- VESA bolt compatible
- max weight = 50lbs
- LCD max size = 23"



not recommended for plasma or CRT units

INTERNAL SHELF KIT

COY-IS-CK

- presents products or literature
- comes with 2 clear acrylic shelves to be used horizontally or at 45° angles
- max capacity per shelf = 15 lbs, max per quadrant = 45 lbs
- for use with curved frame only
- lighting package available (not to be stored with display in OCP)



COYOTE™ TOWER

COY-3-G-TOW

- an unexpected addition to any display; large or small, exhibit or P.O.P.
- back-lit panels illuminate your graphics
- coordinates with the look and style of your Coyote™ popup display





BOLD.SOPHISTICATED.FABRIC. FORMULATE™ TENSION FABRIC

Formulate™ is a collection of sophisticated, ergonomically-designed exhibit booths, architectural structures and accessories • Formulate displays feature simple and stylish aluminum frames, covered by stretch pillowcase fabric graphics • Formulate tension fabric displays are made in the USA and are of the utmost quality and durability • Available in a variety of sizes and options

WHERE **FORM** MEETS **FABRIC**

From straight and angular shapes to ergonomic, flowing ones we offer a full spectrum of beautiful fabric-based exhibits, environments and structures, portable to custom. Make your exhibit and environment exactly what you want it to be. Formulate™ solutions combine shape, specialty fabrics, lightweight frames and lighting to create captivating and artistic presentations and spaces.

Shapes to mix & match...

Lightweight aluminum frames are coupled with stretch, zipper pillowcase fabric graphics to create shapes that foster emotion, action and movement within and around a space. Made in the USA, Formulate fabric structures are formed with expert aluminum bending machinery and skilled welding technicians. We offer a complete line of tension fabric backwalls, exhibit kits, hanging shapes and structures, towers, archways, walls, rooms and more. With the endless options we provide, you can mix and match to create the ideal display, booth or environment or work with us to create a custom solution from scratch.

From fast, portable, off-the-shelf displays to completely custom FABRICated exhibits and solutions, we deliver the solution you need in the time that you need it. Whether you are looking for a tension fabric tradeshow display, or adding function through form in an interior space or retail environment, we provide a one-stop-shop for both sides of the spectrum and everything in between.

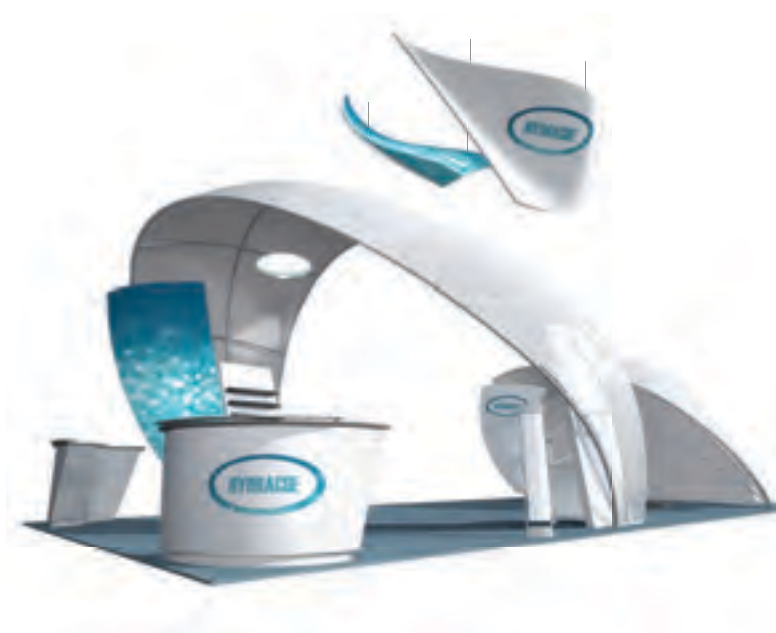

WHERE **FABRIC** MEETS **FORM**

Specialty fabrics...

Materials do matter. Each fabric used has unique qualities and performs differently in various environments. We use a plethora of high-quality printable materials to create fabric structures and displays – namely polyester materials such as stretch, satins, sheers, backlit fabrics and more.

Grand format graphics & finishing...

Graphics are crucial to maximizing your messaging impact and your investment in a tradeshow or event. With the latest state-of-the-art printing technology and large format printing capabilities, we ensure your message pops and stands out from the competition. To ensure the highest quality and perfect fit, all fabric graphics are produced and finished by hand by highly-skilled sewers in the USA.

Radiant lighting ...

The perfect balance of form, fabric and lighting can create a powerful, impactful presence and display. Illumination is an important piece of the puzzle to achieve the mood, style and staging that you desire. With LED lighting kits and solutions, we can tailor the ideal lighting system to make your project glow!

Merging shapes and structures with fresh fabric, large format print graphics and lighting creates dynamic and eye-catching displays for tradeshows, events, retail spaces and interior environments.





Formulate VC10
FMLT-WV10-10

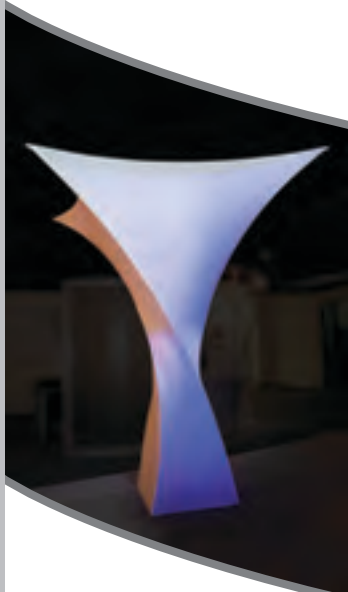

Courtesy of: Neebo & Lines and Designs

FORMULATE TENSION **FABRIC**

The FORMulate™ line spans from a collection of portable, off-the-shelf exhibit kits, hanging structures and architectural accessories to custom-designed and built exhibits, environments and interior display solutions. Formulate combines state-of-the-art zipper pillowcase dye-sublimated fabric coverings with advanced lightweight aluminum tube structures to provide elegance, functionality and style.

The excellence and quality of the Formulate line is simply unmatched. The perfect combination of form, sophistication and function make Formulate displays the ideal solution for any space. All Formulate frames are manufactured in the USA and all Formulate stretch fabric graphics are printed on state-of-the-art, G7 color certified printers and are hand-sewn, durable and dry-cleanable.

The Formulate line includes tabletop, 8ft, 10ft and 20ft backwalls and exhibit kits, 20ft by 20ft island exhibit kits, hanging structures, towers, columns, funnels, archways, counters and more. Easily mix and match to create your ideal display, exhibit or environment or work with us to create a custom solution from scratch.

NO MATTER WHAT YOUR SPACE NEEDS, WE CAN **FORM** A SOLUTION FOR YOU.



formulate™ | TABLETOP DISPLAYS, 8' DISPLAYS

FORMULATE TABLETOP DISPLAYS

Having a small space doesn't mean you can't make a big impact! Formulate™ Tabletop displays are lightweight, highly-portable and come in Straight and Vertical Curved options. The frame assembles with easy-to-use snap buttons, then simply pull the pillowcase fabric graphic over the frame and zip. All displays have an overall height of 46.5 inches, fit on a 6ft wide table and come in a convenient, wheeled transit case.



Formulate TT1
FMLT-WTT-V01

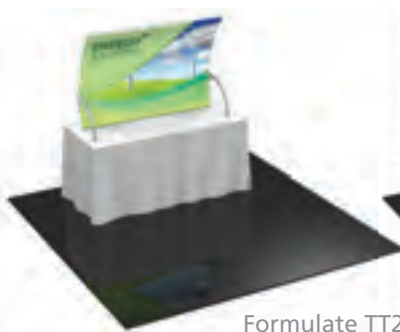

Formulate TT2
FMLT-WTT-V02



Formulate TT3
FMLT-WTT-V03



Formulate TT4
FMLT-WTT-S01

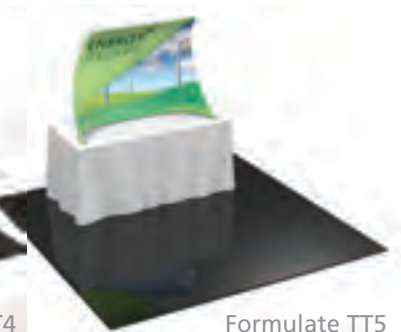

Formulate TT5
FMLT-WTT-S02

FORMULATE 8' DISPLAYS

Simplicity and style make Formulate™ 8ft displays an ideal solution. Available in Straight, Vertical Curved and Horizontal Curved options, Formulate 8ft displays are easy-to-assemble with snap-button tube functionality and pull-over zipper pillowcase fabric graphics. All displays come in a portable, wheeled transit case.



Formulate 8S
FMLT-WS8-01



Formulate 8H
FMLT-WH8-01



Formulate 8V
FMLT-WV8-01

FORMULATE LITE
8'/10' DISPLAYS

Looking for a sharp, simple, portable fabric backdrop that sets up in 5 minutes or less? Look no further. The Formulate™ Lite 8ft by 10ft fabric backdrop is one of the fastest and easiest solutions you can find. In addition to the standard landscape/horizontal configuration, Formulate Lite can be turned on its side to create a portrait/vertical wall as well.

The sturdy, lightweight 30mm aluminum frame assembles with push-button functionality. Simply stretch the graphic over the corners of the frame and you're done. You have an instant, impressive fabric backdrop!

The Formulate Lite kit is supplied in a carry bag. Shown with an optional, upgraded case.



Formulate Lite -
landscape/horizontal graphic



Formulate Lite - portrait/vertical graphic
FMLT-LT-01



formulate™ | 10' VERTICAL CURVED DISPLAYS

FORMULATE 10' VERTICAL CURVED DISPLAYS

Slightly arched from top to bottom, Formulate™ 10ft Vertical Curved exhibits combine pillowcase fabric graphics with lightweight aluminum tube frames to form fashionable and functional exhibits. Accessories such as headers, adjustable literature holders, tables and accents provide enhanced functionality and more real estate for messaging. The wide array of Formulate Vertical Curved kits and accessories make it easy to glamorize any 10ft space.





Formulate VC1
FMLT-WV10-01



Formulate VC2
FMLT-WV10-02



Formulate VC3
FMLT-WV10-03



Formulate VC4
FMLT-WV10-04



Formulate VC5
FMLT-WV10-05



Formulate VC6
FMLT-WV10-06



Formulate VC7
FMLT-WV10-07



Formulate VC8
FMLT-WV10-08



Formulate VC9
FMLT-WV10-09



Formulate VC11
FMLT-WV10-11

LCD monitors not included.

formulate™ | 10' HORIZONTAL CURVED DISPLAYS

FORMULATE 10' HORIZONTAL CURVED DISPLAYS

Ergonomically designed, Formulate™ 10ft Horizontal Curved exhibits combine the latest developments in fabric printed technology with a gently curved aluminum frame to create a seamless, elegant exhibit that enhances the message of your exhibit or environment. Accents provide added functionality and messaging areas. With so many choices, you're sure to find a design that suits your desire for style!



Formulate HC6
FMLT-WH10-06



Courtesy of: Hanscom
Federal Credit Union

10' HORIZONTAL CURVED DISPLAYS | **formulate™**



Formulate HC1
FMLT-WH10-01



Formulate HC2
FMLT-WH10-02



Formulate HC3
FMLT-WH10-03



Formulate HC4
FMLT-WH10-04



Formulate HC5
FMLT-WH10-05



Formulate HC7
FMLT-WH10-07



Formulate HC8
FMLT-WH10-08



Formulate HC9
FMLT-WH10-09



Formulate HC10
FMLT-WH10-10

LCD monitors not included.

formulate™ | 10' STRAIGHT DISPLAYS

FORMULATE 10' STRAIGHT DISPLAYS

Space maximizing Formulate™ 10ft Straight exhibits incorporate sleek, straight aluminum frames with zipper pillowcase fabric graphics to create a sharp, bold backwall that clearly conveys who you are and what you do. With a variety of accents including graphic headers, adjustable literature pockets, shelves, tables, counters and more, you are sure to find a design that best suits your space needs!



Formulate S5
FMLT-WS10-05



Formulate S1
FMLT-WS10-01



Formulate S2
FMLT-WS10-02



Formulate S3
FMLT-WS10-03



Formulate S4
FMLT-WS10-04



Formulate S6
FMLT-WS10-06



Formulate S7
FMLT-WS10-07

FORMULATE ACCENTS

Formulate™ accents enhance the functionality of any Formulate 10ft or 20ft backwall and add more real estate for messaging too! With monitor supports, literature pockets, shelves, tables, counters and more, you are sure to find the accent that best suits your needs. Side tables and graphic headers also available.

FORMULATE BACKWALL CONNECTOR
FMLT-WBWC

The Formulate™ Backwall Connector is an ideal accessory to connect two 10ft or 20ft Formulate backwalls. It features a pillowcase fabric graphic and connects easily to create the appearance of one seamless display.

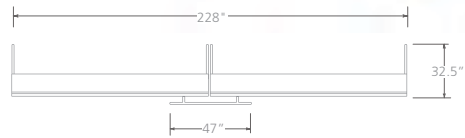
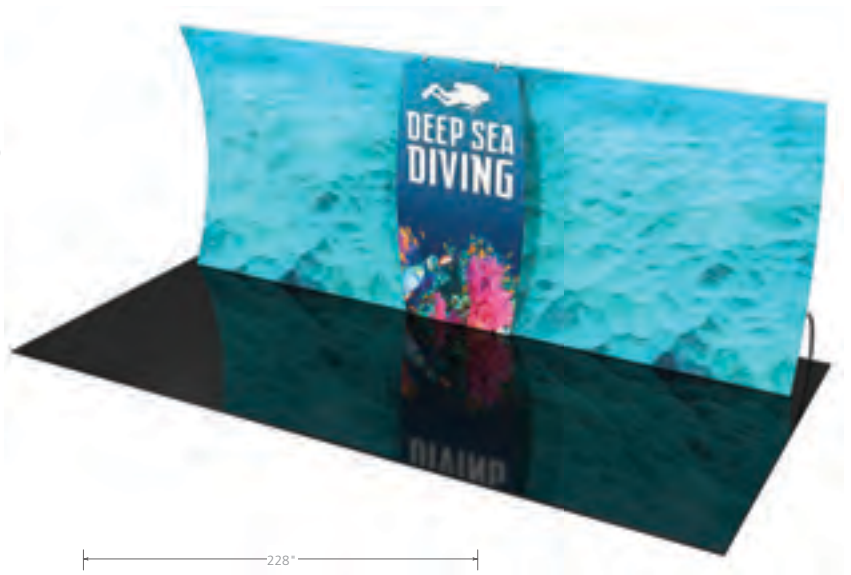

ACCENT 01
FMLT-WL01
Pillowcase fabric graphic.



ACCENT 02
FMLT-WL02
Three 20 inch wide shelves and top and bottom printed infill panels.



ACCENT 03
FMLT-WL03
FMLT-WL03-L
FMLT-WL03-R
Your choice of right-hand or left-hand arm tables, no table, top and bottom printed infill panels and hardware mounts for a medium sized monitor.



ACCENT 04
FMLT-WL04
Features a 36 inch wide table top, top and bottom velcro applied printed fabric graphics and hardware mounts for a large monitor.



ACCENT 05
FMLT-WLLH
Three literature pockets, and top and bottom printed infill panels.



ACCENT 06
FMLT-WLC
Features a 20 inch wide shelf and top and bottom printed infill panels.

LCD monitors not included.

formulate™ | 20' SERPENTINE CURVED DISPLAYS

FORMULATE 20' SERPENTINE CURVED DISPLAYS

The gentle and organic S-shaped curves of the Formulate™ Serpentine line of 20' exhibits create an elegant flow within a space. These displays can feature a single-sided or double-sided fabric graphic, which provides more real estate for branding and messaging. Pillowcase style fabric graphics are coupled with sturdy, yet lightweight aluminum frames to create the unique and flowing Serpentine shape. Accents provide shelving, surface areas, monitor displays and additional messaging areas.



Formulate SC2
FMLT-WSC-20-02

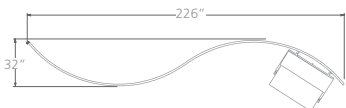

Courtesy of: Hamilton Exhibits

20' SERPENTINE CURVED DISPLAYS

formulate™



Formulate SC1
FMLT-WSC20-01

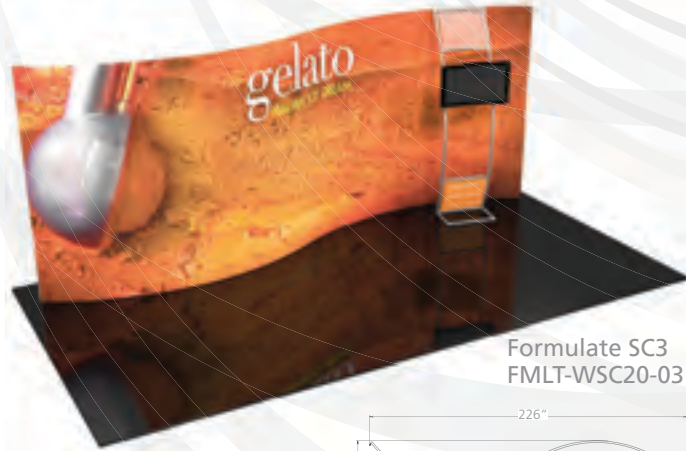
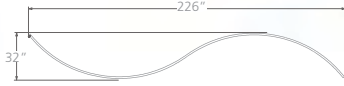

Formulate SC3
FMLT-WSC20-03



Formulate SC4
FMLT-WSC20-04

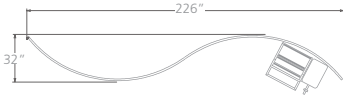

Formulate SC5
FMLT-WSC20-05

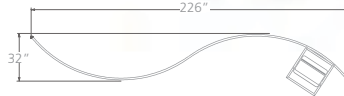

Formulate SC6
FMLT-WSC20-06

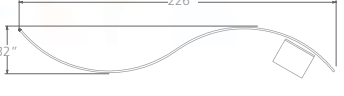

LCD monitors not included.

formulate™ | 20' VERTICAL CURVED DISPLAYS

FORMULATE 20' VERTICAL CURVED DISPLAYS

Slightly arched from top to bottom, Formulate™ 20ft Vertical Curved displays combine pillowcase fabric graphics with lightweight aluminum tube frames to form fashionable and functional exhibits. Accents provide enhanced functionality and more real estate for messaging. The wide array of Formulate Vertical Curved kits and accessories make it easy to glamorize any 20ft space.



Formulate WV3
FMLT-WV20-03

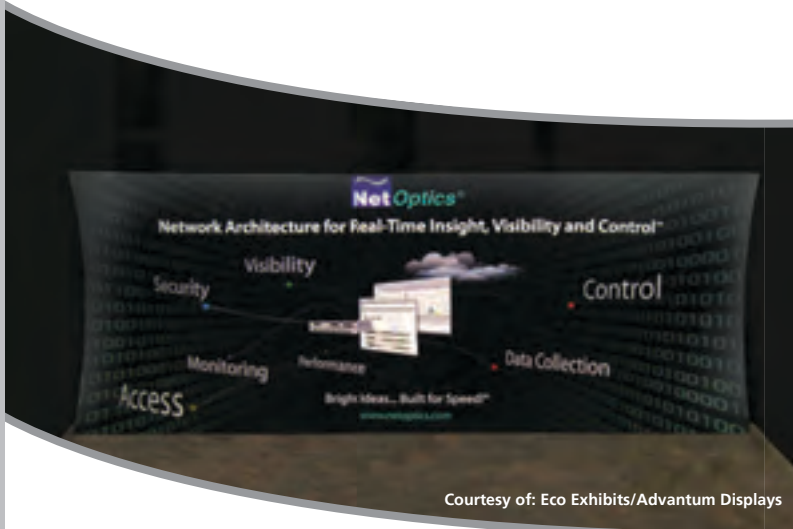

Courtesy of: Eco Exhibits/Advantum Displays



Courtesy of: Eye Catching Solutions

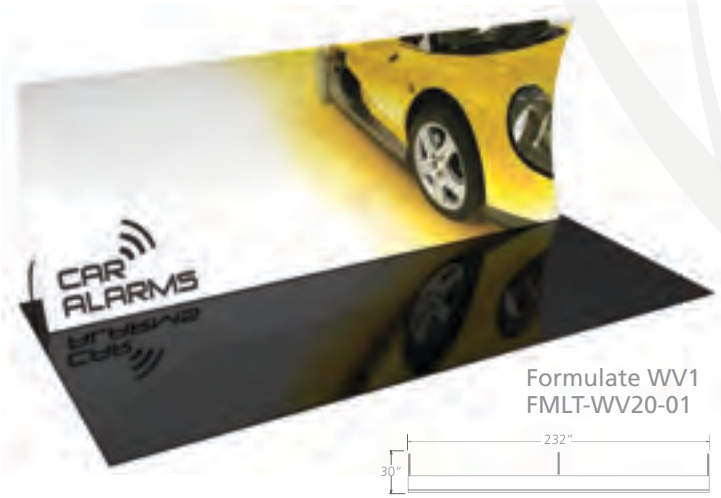

LCD monitors not included.

formulate™ | 20' HORIZONTAL CURVED DISPLAYS

FORMULATE 20' HORIZONTAL CURVED DISPLAYS

Ergonomically designed, Formulate™ 20ft Horizontal Curved exhibit kits combine the latest developments in fabric printed technology with a gently curved aluminum frame to create a seamless, elegant exhibit that enhances the message of your exhibit or environment. Accents provide added functionality and messaging areas. With so many choices, you're sure to find a design that suits your desire for style!



Formulate WH4
FMLT-WH20-04

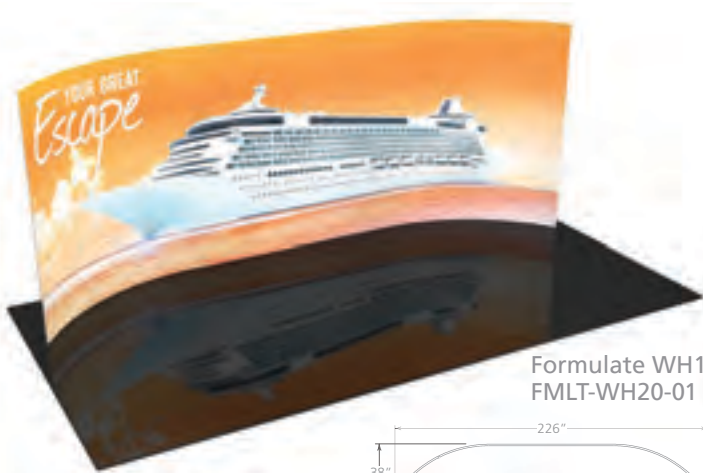

Formulate WH1
FMLT-WH20-01



Formulate WH2
FMLT-WH20-02





Formulate WH3
FMLT-WH20-03



Formulate WH5
FMLT-WH20-05



Formulate WH6
FMLT-WH20-06

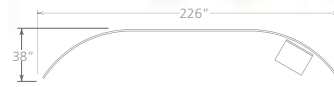

LCD monitors not included.



Formulate 20 Straight
FMLT-WS20-01



FORMULATE 20' STRAIGHT DISPLAY

The Formulate™ 20ft Straight backwall incorporates a sleek, straight aluminum frame with a zipper pillowcase fabric graphic to create a sharp, bold backwall that clearly conveys who you are and what you do. Print on just one side or on both sides of the graphic to maximize your message and brand exposure!

SPIN OR FLIP

TO CREATE A DIFFERENT LOOK
& SHOW A NEW MESSAGE!

 **SPIN** FROM **FRONT TO BACK** TO SHOW A
DIFFERENT MESSAGE OR BRAND! 



FLIP 20' EXHIBIT KITS

FLIP™ 20ft exhibits incorporate layered, staggered walls that are connected to create a unique, dimensional and versatile display.

SO FLIPPIN' COOL

Double-sided graphics enable you to feature a different look, brand or messaging so you can **SPIN from front to back** OR use as a creative space divider for a larger space. With an easy graphic change, you can also **FLIP from top to bottom** to create a new, different exhibit and look for your next event. With the versatility of FLIP, you have many options to reconfigure over and over for a long-lasting, ever-changing display.

SO FLIPPIN' EASY

FLIP kits combine 30mm lightweight aluminum frames with your choice of single or double-sided zipper pillowcase fabric graphics. Simply join the aluminum tubes together with snap-button connectors, slide the fabric graphics over the frames, then zip. Connect the walls and WHALA, you have one of the coolest and most versatile displays in the event. It's that easy.

FLIP FROM TOP TO BOTTOM TO CREATE A NEW LOOK FOR ANOTHER EVENT!

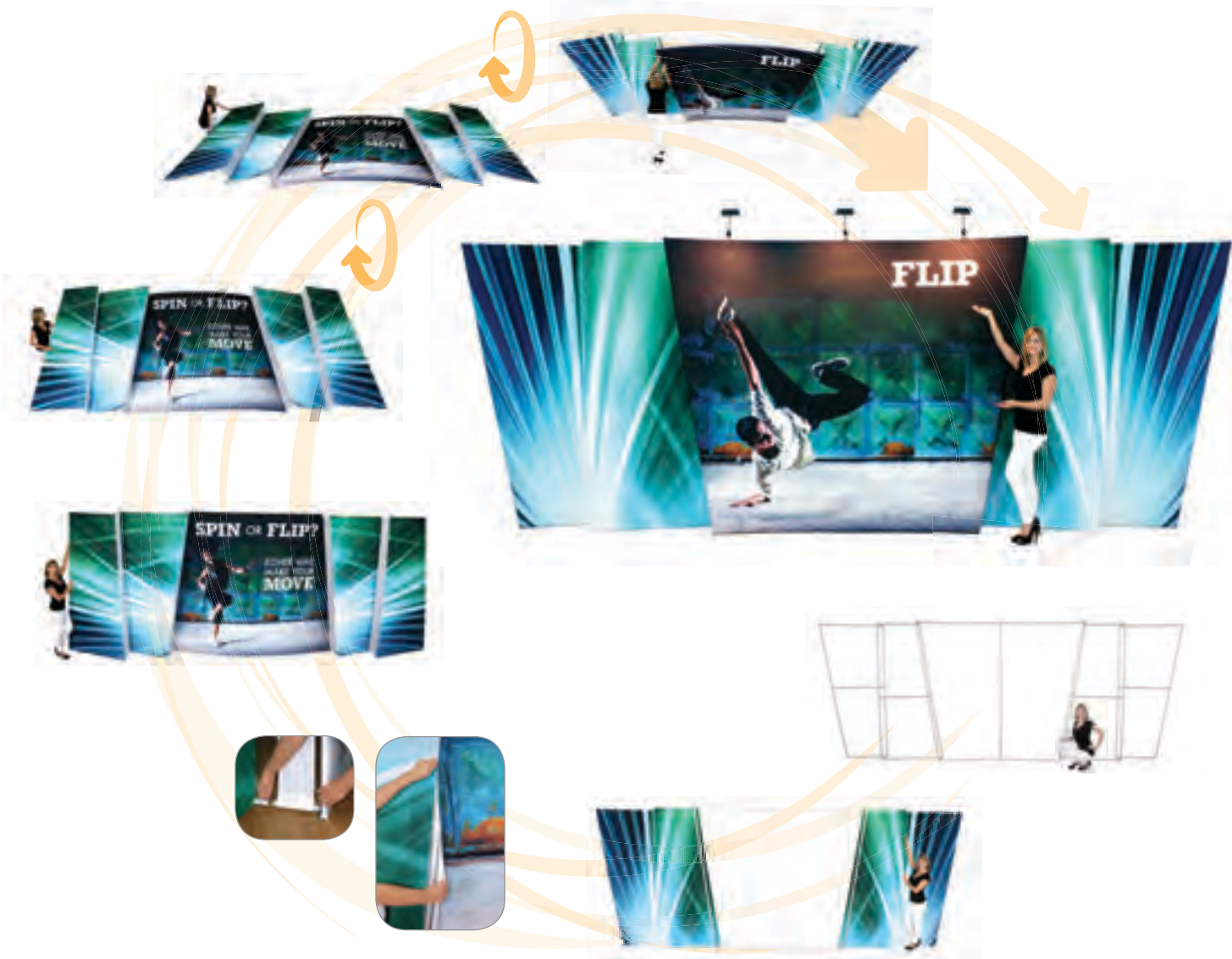

FLIP 20' EXHIBIT KITS

FLIP™ 20ft exhibits incorporate layered, staggered walls that are connected to create a unique, dimensional and versatile display.



FLIP-01

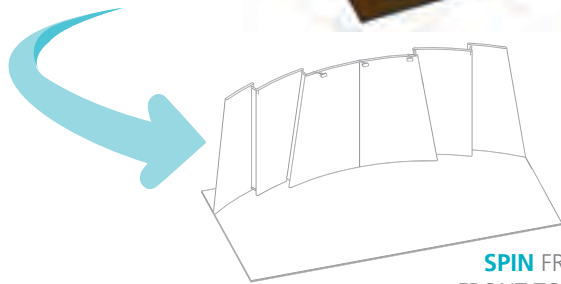

SPIN FROM FRONT TO BACK

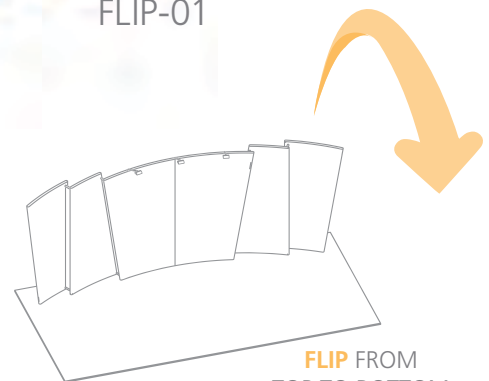

FLIP FROM TOP TO BOTTOM



FLIP-02

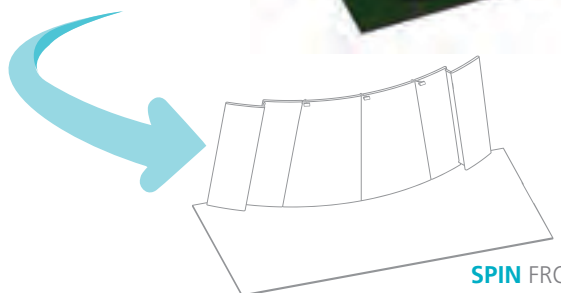

SPIN FROM FRONT TO BACK

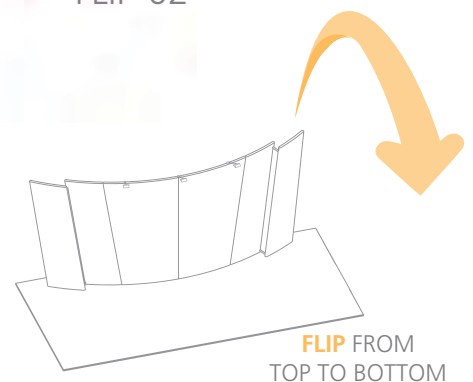

FLIP FROM TOP TO BOTTOM

*Counters, lighting and lighting hardware not included in kits. A la carte counter options presented on page 112. Lighting presented on page 123.

FLIP 20' EXHIBIT KITS

Easily incorporate LED strip lights and related hardware kits between the staggered walls to make your FLIP™ display shine.



FLIP-03

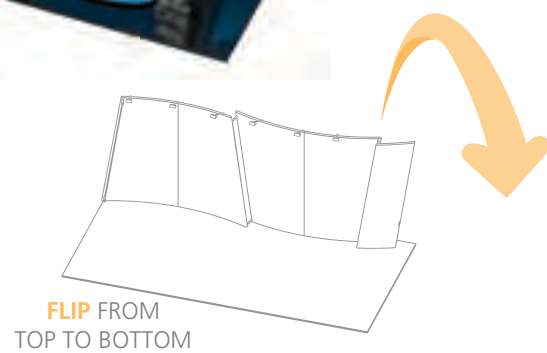
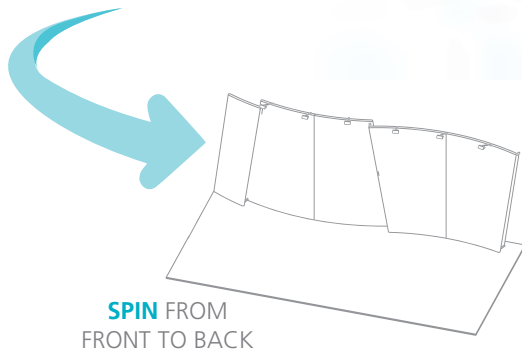

FLIP-04

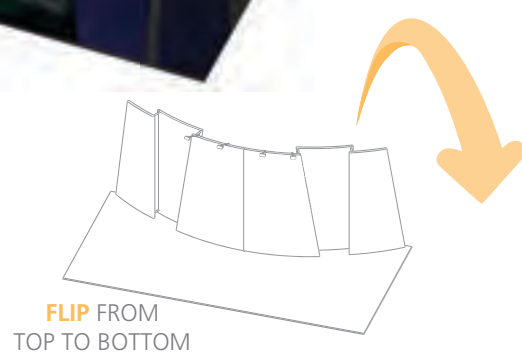
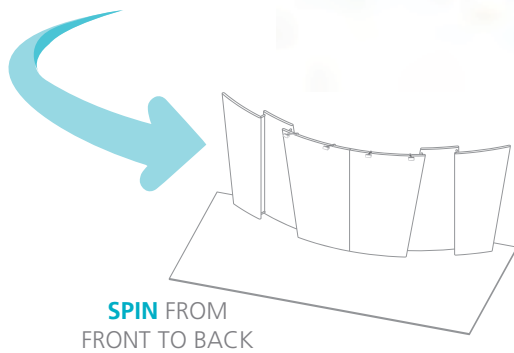

*Counters, lighting and lighting hardware not included in kits. A la carte counter options presented on page 112. Lighting presented on page 123.

VIBE 10' EXHIBIT KITS

Vibe™ is a collection of cleverly-designed, dimensionally layered 10ft exhibit kits. Vibe combines layered lightweight aluminum tube frames with zippered pillowcase printed fabric graphics. Unique shapes, angles and exposed framework create a truly unique appearance and experience. Where they appear, kits include graphic headers, lights and monitor kiosks to provide additional branding and messaging areas.



KIT 05
VBK-5



KIT 01
VBK-1



KIT 02
VBK-2



KIT 03
VBK-3



KIT 04
VBK-4



KIT 06
VBK-6



**VIBE MONITOR
KIOSK**
VB-MK-01

Simply add the Vibe™ kiosk to create an interactive, multimedia display. Kiosk comes with a monitor bracket that holds a max weight of 50lbs and a convenient, portable shipping case. Monitor is not included with kiosk or kit.

formulate™ fusion | 20' x 20' ISLAND EXHIBIT KITS

FORMULATE FUSION

Formulate™ Fusion provides an unparalleled dynamic that elevates and accentuates a message and brand, but also maximizes the return on tradeshow investment. Formulate Fusion is a collection of 20ft by 20ft exhibit kits and custom solutions. A fusion of FORM, FABRIC and FUNCTION, these kits combine organic and architectural shapes with state-of-the-art zipper pillowcase dye-sublimated fabric graphics to create unique, dynamic and functional island spaces.

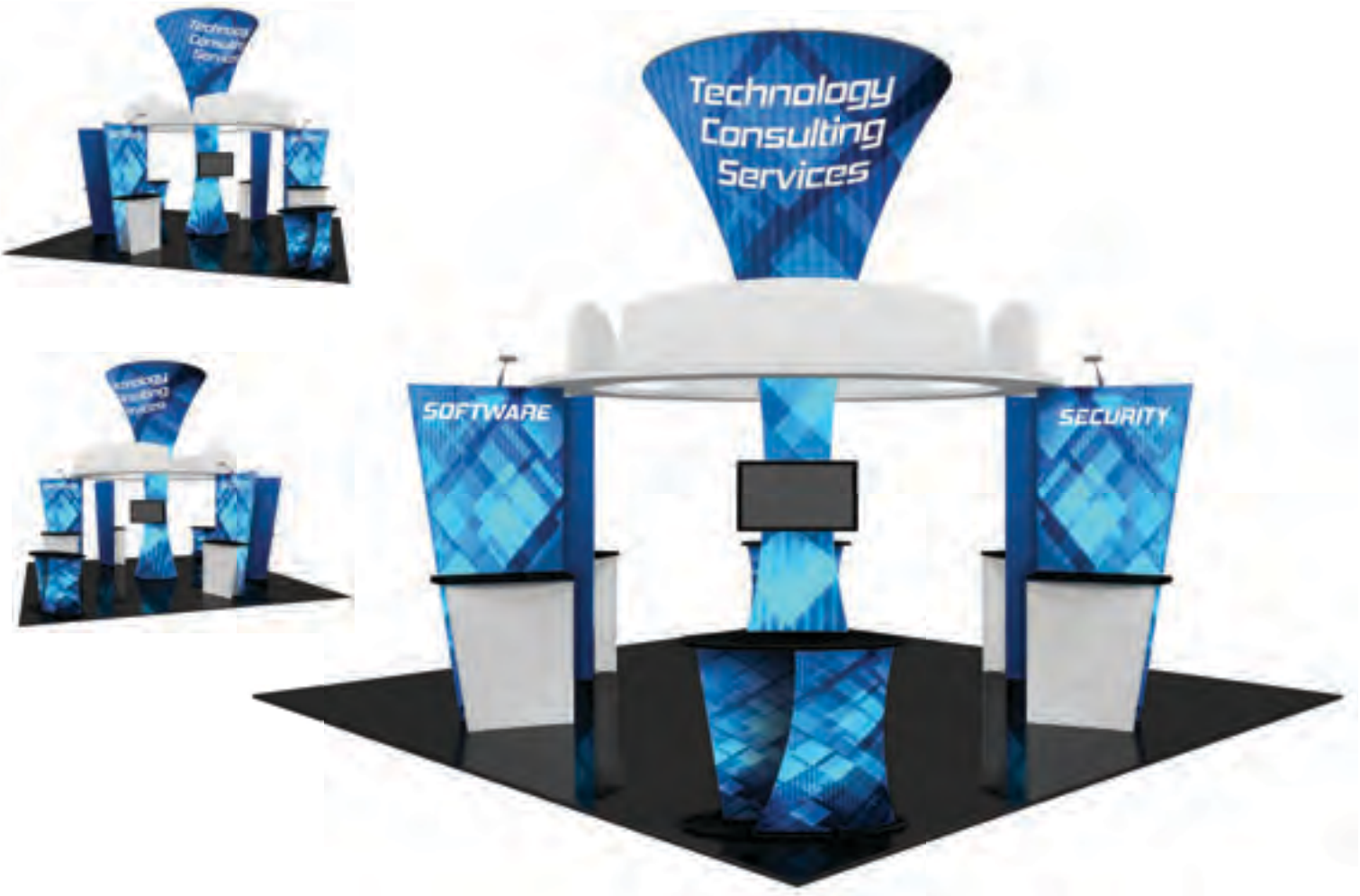

KIT 01

CFAB-K-01

Add the WOW factor to your next tradeshow with this commanding and captivating 20ft by 20ft island display.

Formulate™ Fusion Kit 1 weaves together FORMulated structures that combine the latest developments in fabric printed technology with heavy-duty, structurally-sound aluminum frame structures to create a space that encourages traffic flow and provides stylish product display and messaging areas.

The 16ft tall fabric tower centerpiece connects to four 8ft tall fabric-based product display areas. A 14ft diameter ring structure not only provides an ideal area for branding and messaging, but it also weaves the elegant tower and product display areas together. Two fabric reception counters provide fashionable, and functional greeting areas. Monitor mounts and stylish display lighting are included. Internal LED light kits are not included, but can be purchased a la carte to add a glow within the tower and reception counters.

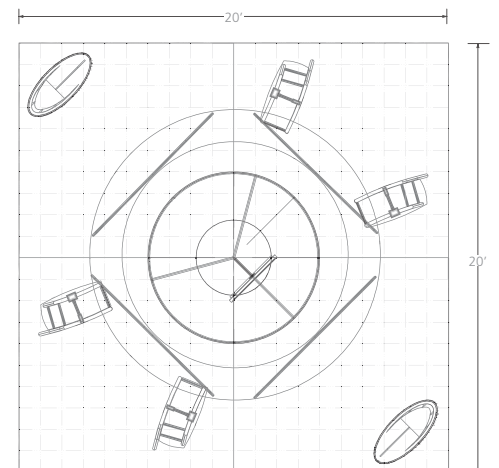



KIT 02
CFAB-K-02

You won't get bypassed with this 20ft by 20ft island exhibit in your next event or tradeshow!

Formulate™ Fusion Kit 2 features a fabric archway, a dimensional hanging structure and curved conference area to create a space that fosters flow, yet provides privacy for meetings and demonstrations. Each display element combines state-of-the-art zipper pillowcase dye-sublimated fabric coverings with advanced lightweight aluminum tube structures.

The overhead hanging structure is 13ft wide, 5ft tall and 1ft thick, providing ample space for a company brand. The prominent arch spans 14ft wide and reaches 11 ½ft high. An 8ft tall by 9 ½ft wide fabric backwall is positioned behind the fabric display counter to add a messaging area, privacy and a display surface on the interior side. An 8ft tall "potato chip" shaped, curved fabric wall creates a semi-private conference/meeting area or projection wall within the space. Monitor mounts and stylish display lighting are included. Internal LED light kits are not included, but can be purchased a la carte to add a glow within the reception counter and backwall.

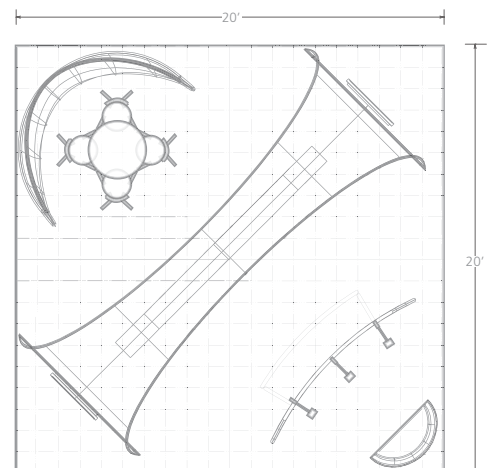



KIT 03
CFAB-K-03

Captivate your audience inside this 20ft by 20ft island display at your next event!

Formulate™ Fusion Kit 3 features a commanding and angled fabric architectural structure, reception areas and more! The angled, architectural tunnel is 16ft tall on one side and 12ft tall on the other and is the perfect space for an intimate and semi-private presentation, conference or theater area. This stylish and functional island display kit also includes two fabric-based reception counters that function as ideal greeting and storage areas. Additionally, a fabric-based refreshment bar is located inside the theater space, which also features additional storage space.

Monitor mounts and stylish display lighting are included. Internal LED light kits are not included, but can be purchased a la carte to add a glow within the reception counters.

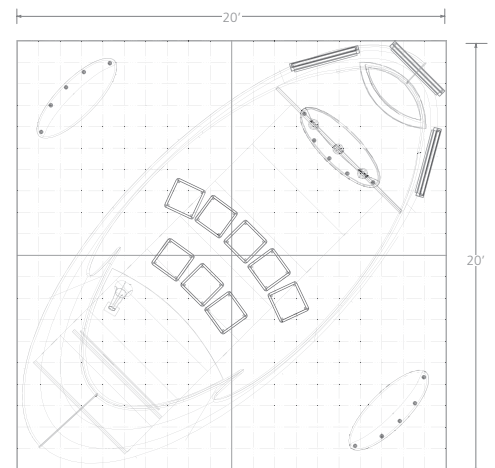



KIT 04
CFAB-K-04

Demo, demo, demo! You have ample demonstration and meeting space with this 20ft by 20ft island exhibit!

Fabric canopies and messaging areas are combined with a heavy-duty laminate-based tower and cabinets to create a space that provides three product display/demonstration stations and two seating areas. The layout of this exhibit fosters traffic flow within the space and provides real estate for demonstrations.

Formulate™ Fusion Kit 4 features an 18ft tall laminate panel tower connected to three 12ft long wave-shaped canopies. The tower features ample lockable storage space. Stemming from the three canopies are 10 ½ft tall fabric and extrusion based messaging and product display walls, which are anchored to laminated, lockable cabinets. Graphic headers on the display walls are 4ft wide and provide the ideal space for branding or product information.

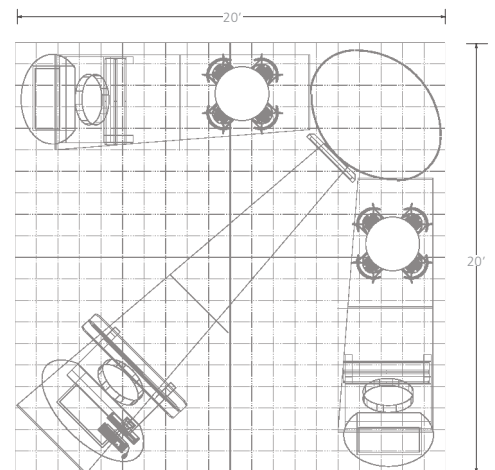

formulate™ fusion | 20' x 20' ISLAND EXHIBIT KITS



KIT 05 CFAB-K-05

Dominate the exhibit hall with this 20ft by 20ft island exhibit and stand out from the rest!

Formulate™ Fusion Kit 5 combines architectural lines and shapes with the latest developments in fabric to create a sophisticated, memorable and breathtaking presence.

The 18ft tall fabric covered tower centerpiece features a 7ft diameter cone and three curved architectural support beams. You can easily incorporate monitors and AV into the support structures to add multimedia messaging. A laminate counter with wooden slat walls provides a welcoming reception area, as well as abundant lockable storage.

Monitor mounts are included. Internal LED light kits are not included, but can be purchased a la carte to add a glow within the support structures.

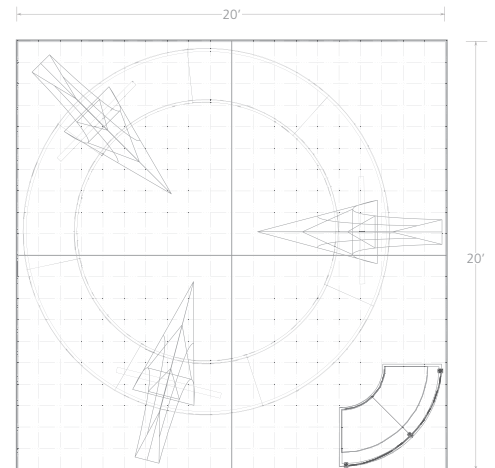

CUSTOM FORMULATE

We can also FABRICate a completely custom and ultra-creative exhibit and environment solution for you. Each custom FORMulated solution is uniquely designed, manufactured and custom crafted from a selection of sizes and styles of aluminum tube, which are blended with the very best-suited stretch fabric graphics and lighting.

With over 30 years of proven excellence in the design, construction, project management and fulfillment of custom and custom modular exhibit solutions, we have what it takes to build a custom booth, environment and interior space. Concept to design, then design to production, we can provide custom fabric exhibit structures as a seamless turnkey service through to installation, dismantle and post-show storage.



KIT 06
CFAB-K-06

An airy floor plan encourages maximum traffic flow into this 20ft by 20ft island exhibit!

Formulate™ Fusion Kit 6 features structures that combine the latest developments in fabric printed technology with heavy-duty aluminum frames to create a space that fosters great traffic flow and conversation areas.

The 12ft tall center fabric tower is connected to two 9ft tall fabric towers via exposed aluminum tube. Oval-shaped sintra panels are located on front and back sides of the aluminum tubes providing four messaging and branding areas. An oval-shaped fabric reception counter provides a fashionable, yet functional greeting area. Additionally, an 8ft tall "potato chip" shaped, curved fabric wall creates a semi-private conference/meeting area or projection wall within the space.

Six monitor mounts are included. Internal LED light kits are not included, but can be purchased a la carte to add a glow within the three tower structures and reception counter.

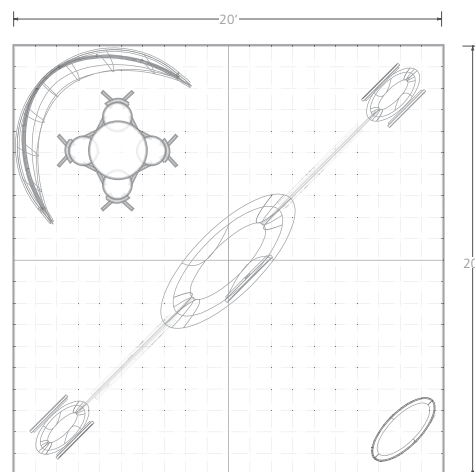

FORMULATE HANGING STRUCTURES

Hanging structures are used to attract and command attention to your tradeshow booth or use as a focal point at an event or in an interior space. Project from all angles and draw the eye to your brand to proclaim your message! With a wide variety of three and two-dimensional structures and shapes to choose from, you're sure to find the best solution to draw attention and create a dramatic affect in any space.

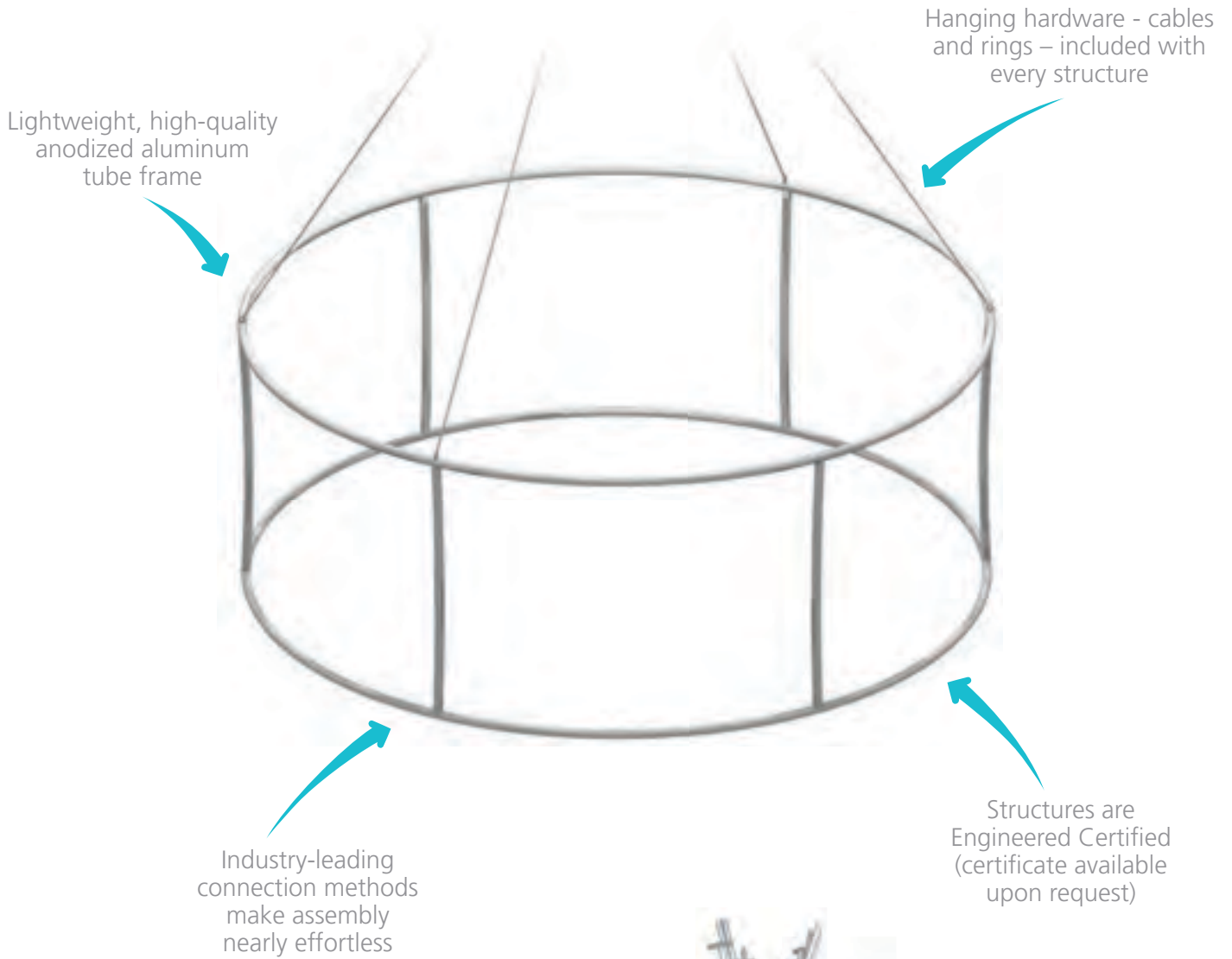

OCE – Formulate Expandable Case

Structures collapse to a fraction of their size and come in standard in carry bags and heavy-duty shipping and storage box(es).

Expandable, rugged molded shipping and transportation cases available as an upgrade.

Formulate™ tension fabric hanging structures are made in the USA and are of the utmost quality and durability. Formulate combines state-of-the-art zipper pillowcase dye-sublimated stretch fabric coverings with advanced, lightweight aluminum structures to provide unique design, functionality, and style. The excellence of the Formulate line of hanging structures is simply unmatched!

Fabric printing process provides G7 color-certified, SUPERIOR brilliant and vivid graphics

Tensioned, zippered pillowcase style fabric graphics are easy to slip on and off



Stretch fabric graphics are hand-sewn, durable and dry-cleanable

All graphics come with an opaque liner at no additional cost



Choose from these graphic options:
Blank, single-sided, double-sided,
and zip-in blank and printed
bottom panels

RING

- 8' diam. x 2'h/3'h/4'h/5'h/6'h
- 10' diam. x 2'h/3'h/4'h/5'h/6'h
- 12' diam. x 2'h/3'h/4'h/5'h/6'h
- 14' diam. x 2'h/3'h/4'h/5'h/6'h
- 16' diam. x 2'h/3'h/4'h/5'h/6'h
- 18' diam. x 2'h/3'h/4'h/5'h/6'h
- 20' diam. x 2'h/3'h/4'h/5'h/6'h



double-sided graphic

bottom graphic

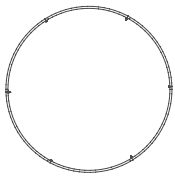

TAPERED RING

- 8' diam. x 2'h/3'h/4'h/5'h/6'h
- 10' diam. x 2'h/3'h/4'h/5'h/6'h
- 12' diam. x 2'h/3'h/4'h/5'h/6'h
- 14' diam. x 2'h/3'h/4'h/5'h/6'h
- 16' diam. x 2'h/3'h/4'h/5'h/6'h
- 18' diam. x 2'h/3'h/4'h/5'h/6'h
- 20' diam. x 2'h/3'h/4'h/5'h/6'h



double-sided graphic

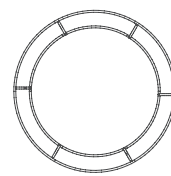

SQUARE

- 8'w x 2'h/3'h/4'h/5'h/6'h
- 10'w x 2'h/3'h/4'h/5'h/6'h
- 12'w x 2'h/3'h/4'h/5'h/6'h
- 14'w x 2'h/3'h/4'h/5'h/6'h
- 16'w x 2'h/3'h/4'h/5'h/6'h
- 18'w x 2'h/3'h/4'h/5'h/6'h
- 20'w x 2'h/3'h/4'h/5'h/6'h



double-sided graphic



bottom graphic

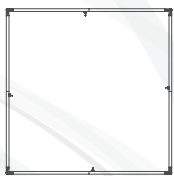

TAPERED SQUARE

- 8'w x 2'h/3'h/4'h/5'h/6'h
- 10'w x 2'h/3'h/4'h/5'h/6'h
- 12'w x 2'h/3'h/4'h/5'h/6'h
- 14'w x 2'h/3'h/4'h/5'h/6'h
- 16'w x 2'h/3'h/4'h/5'h/6'h
- 18'w x 2'h/3'h/4'h/5'h/6'h
- 20'w x 2'h/3'h/4'h/5'h/6'h



double-sided graphic

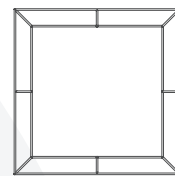

CONCAVE SQUARE

8'w x 2'h/3'h/4'h/5'h/6'h
 10'w x 2'h/3'h/4'h/5'h/6'h
 12'w x 2'h/3'h/4'h/5'h/6'h
 14'w x 2'h/3'h/4'h/5'h/6'h
 16'w x 2'h/3'h/4'h/5'h/6'h
 18'w x 2'h/3'h/4'h/5'h/6'h
 20'w x 2'h/3'h/4'h/5'h/6'h



double-sided graphic

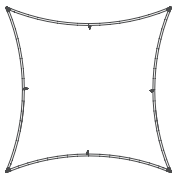

TRIANGLE

8'w x 2'h/3'h/4'h/5'h/6'h
 10'w x 2'h/3'h/4'h/5'h/6'h
 12'w x 2'h/3'h/4'h/5'h/6'h
 14'w x 2'h/3'h/4'h/5'h/6'h
 16'w x 2'h/3'h/4'h/5'h/6'h
 18'w x 2'h/3'h/4'h/5'h/6'h
 20'w x 2'h/3'h/4'h/5'h/6'h



double-sided graphic



bottom graphic

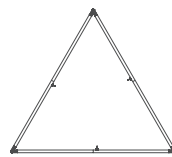

TAPERED TRIANGLE

8'w x 2'h/3'h/4'h/5'h/6'h
 10'w x 2'h/3'h/4'h/5'h/6'h
 12'w x 2'h/3'h/4'h/5'h/6'h
 14'w x 2'h/3'h/4'h/5'h/6'h
 16'w x 2'h/3'h/4'h/5'h/6'h
 18'w x 2'h/3'h/4'h/5'h/6'h
 20'w x 2'h/3'h/4'h/5'h/6'h



double-sided graphic

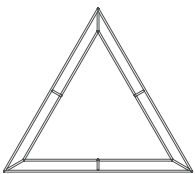

CONVEX TRIANGLE (SHIELD)

8'w x 2'h/3'h/4'h/5'h/6'h
 10'w x 2'h/3'h/4'h/5'h/6'h
 12'w x 2'h/3'h/4'h/5'h/6'h
 14'w x 2'h/3'h/4'h/5'h/6'h
 16'w x 2'h/3'h/4'h/5'h/6'h
 18'w x 2'h/3'h/4'h/5'h/6'h
 20'w x 2'h/3'h/4'h/5'h/6'h



double-sided graphic

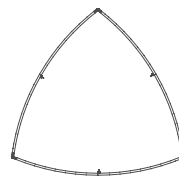

PINWHEEL

- 8'w x 2'h/3'h/4'h/5'h/6'h
- 10'w x 2'h/3'h/4'h/5'h/6'h
- 12'w x 2'h/3'h/4'h/5'h/6'h
- 14'w x 2'h/3'h/4'h/5'h/6'h
- 16'w x 2'h/3'h/4'h/5'h/6'h
- 18'w x 2'h/3'h/4'h/5'h/6'h
- 20'w x 2'h/3'h/4'h/5'h/6'h

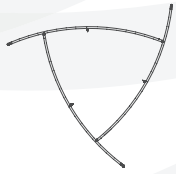

double-sided graphic

RECTANGLE

- 8'w x 2'h/3'h/4'h/5'h/6'h
- 10'w x 2'h/3'h/4'h/5'h/6'h
- 12'w x 2'h/3'h/4'h/5'h/6'h
- 14'w x 2'h/3'h/4'h/5'h/6'h
- 16'w x 2'h/3'h/4'h/5'h/6'h
- 18'w x 2'h/3'h/4'h/5'h/6'h
- 20'w x 2'h/3'h/4'h/5'h/6'h

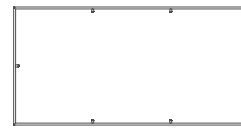

double-sided graphic

FOOTBALL

- 8'w x 2'h/3'h/4'h/5'h/6'h
- 10'w x 2'h/3'h/4'h/5'h/6'h
- 12'w x 2'h/3'h/4'h/5'h/6'h
- 14'w x 2'h/3'h/4'h/5'h/6'h
- 16'w x 2'h/3'h/4'h/5'h/6'h
- 18'w x 2'h/3'h/4'h/5'h/6'h
- 20'w x 2'h/3'h/4'h/5'h/6'h

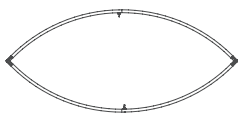

double-sided graphic

FOUR-SIDED PYRAMID

- 10'w x 5'h
- 12'w x 6'h
- 16'w x 8'h
- 20'w x 10'h

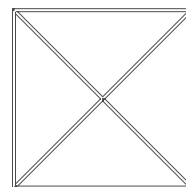

THREE-SIDED PYRAMID

10'w x 5'h
12'w x 6'h
16'w x 8'h
20'w x 10'h

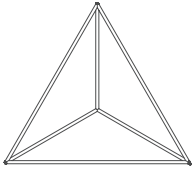

ROUND FUNNEL

10'w x 5'h

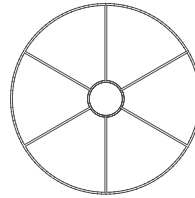

SQUARE FUNNEL

10'w x 5'h

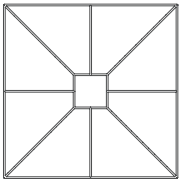

CONE

10'w x 5'h
12'w x 6'h
16'w x 8'h
20'w x 10'h

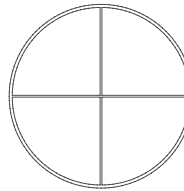

CURVE

8'w x 2'h/3'h/4'h/5'h/6'h
10'w x 2'h/3'h/4'h/5'h/6'h
12'w x 2'h/3'h/4'h/5'h/6'h
14'w x 2'h/3'h/4'h/5'h/6'h
16'w x 2'h/3'h/4'h/5'h/6'h
18'w x 2'h/3'h/4'h/5'h/6'h
20'w x 2'h/3'h/4'h/5'h/6'h



PANEL

8'w x 2'h/3'h/4'h/5'h/6'h
10'w x 2'h/3'h/4'h/5'h/6'h
12'w x 2'h/3'h/4'h/5'h/6'h
14'w x 2'h/3'h/4'h/5'h/6'h
16'w x 2'h/3'h/4'h/5'h/6'h
18'w x 2'h/3'h/4'h/5'h/6'h
20'w x 2'h/3'h/4'h/5'h/6'h



DISC

8' diameter
10' diameter
12' diameter
14' diameter
16' diameter
18' diameter
20' diameter



S-CURVE

8'w x 2'h/3'h/4'h/5'h/6'h
10'w x 2'h/3'h/4'h/5'h/6'h
12'w x 2'h/3'h/4'h/5'h/6'h
14'w x 2'h/3'h/4'h/5'h/6'h
16'w x 2'h/3'h/4'h/5'h/6'h
18'w x 2'h/3'h/4'h/5'h/6'h
20'w x 2'h/3'h/4'h/5'h/6'h



FORMULATE FUNNELS

Whether you are looking for a way to draw attention and captivate your audience at a tradeshow, special event, or in a permanent environment, these FORMulated and tension fabric architectural structures are designed to impress.

Versatile Formulate™ Funnels transform any environment through form, fabric and lighting. Formulate Funnels have an hourglass shape, come in 20ft, 16ft and 12ft heights and have 8ft diameters at the top and 3½ft diameters at the bottom. Funnels feature a heavy-duty, wooden base and silver powder coated truss interior to create a dynamic, towering structure that commands attention. Fabric graphics feature a zipper at the top and a silicone edge at the bottom for easy assembly. Accent LED light kits are not included, but can be purchased a la carte to add a glow within the funnel structures. Custom sizes also available.



20' FUNNEL
FUN-01



16' FUNNEL
FUN-02

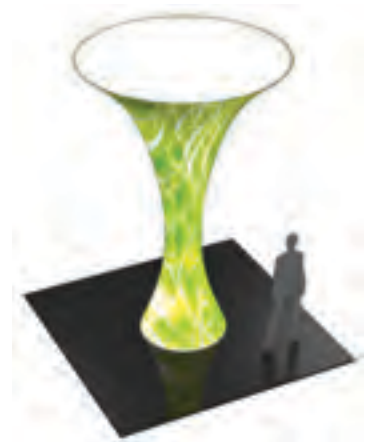

12' FUNNEL
FUN-03

FORMULATE TOWERS

Mix and match the Formulate™ line of towers to add architecture and drama to any event or interior space. Cylinder-shaped and Rectangular-shaped towers come in 12ft, 10ft and 8ft heights and 3ft square/diameters at the tops and bottoms. They combine the latest developments in fabric printed technology with aluminum tube frames to add dimension, décor and sculpture to any event, stage set, tradeshow booth or interior space. Formulate towers accommodate internal LED lighting. Accent LED light kits are not included, but can be purchased a la carte to add a glow within the structures. Custom sizes also available.

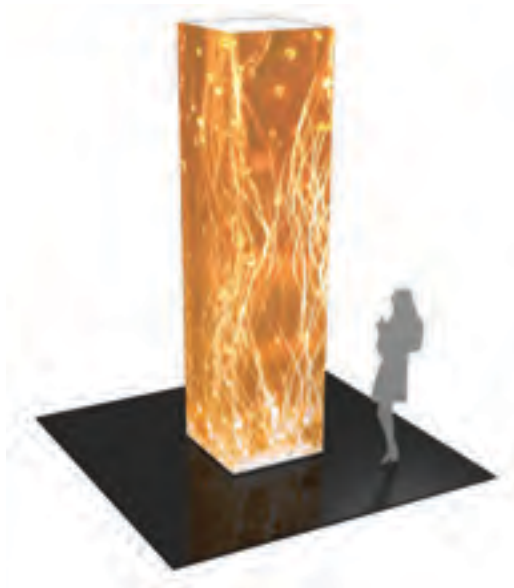

12' FOUR
SIDED TOWER
COL-01

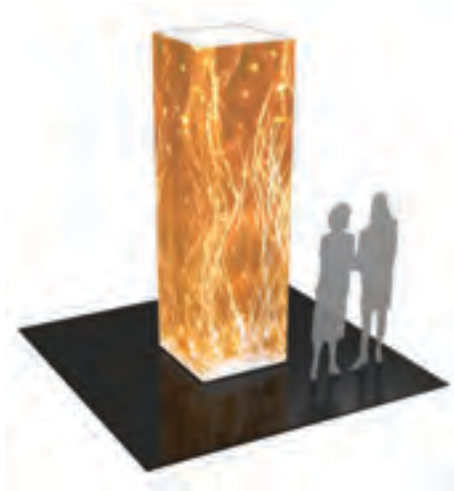

10' FOUR
SIDED TOWER
COL-02



8' FOUR
SIDED TOWER
COL-03

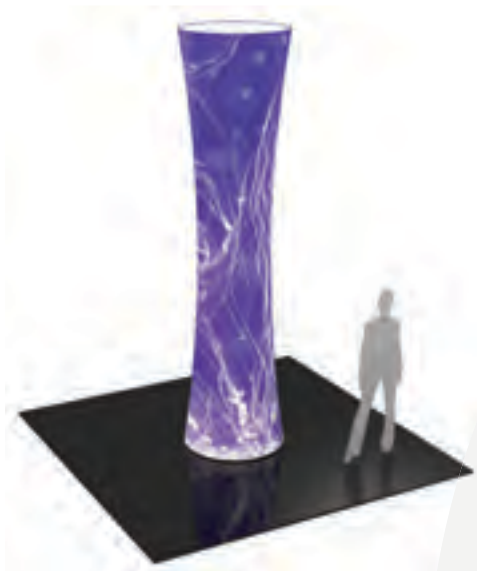

12' CYLINDER TOWER
CYL-01

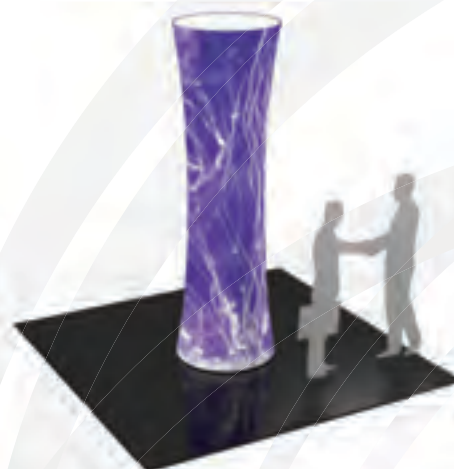

10' CYLINDER TOWER
CYL-02

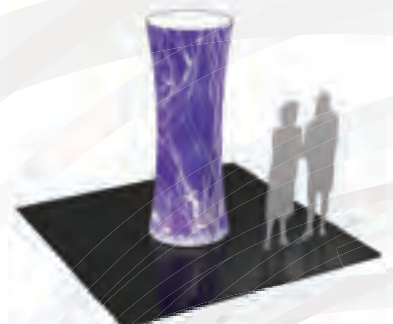

8' CYLINDER TOWER
CYL-03

FORMULATE ARCHES

Formulate™ Arches add architecture and design to any event or interior space! Easily create and define a stunning entryway, focal point or stage set at your next tradeshow or event with Formulate Arches.

Formulate Arches combine pillowcase style stretch fabric graphics with 50mm curved aluminum tube frames; these super structures are made in the USA and collapse to a fraction of their size. Custom sizes also available.



overhead perspective

ARCH 01 12' ARCH-01

The Formulate™ Arch 01 is 8ft tall and spans 11½ft wide. Two monitor mounts are included, externally facing, adding a bonus opportunity to display messaging and branding. Shown in a 12' space.

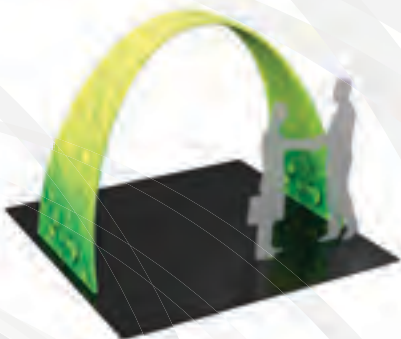

ARCH 02 10' ARCH-02

The Formulate™ Arch 02 is 7⅔ft tall and spans 9½ft wide. Two bases provide weighted stability and serve as anchors for the fabric structure. Shown in a 10' space.

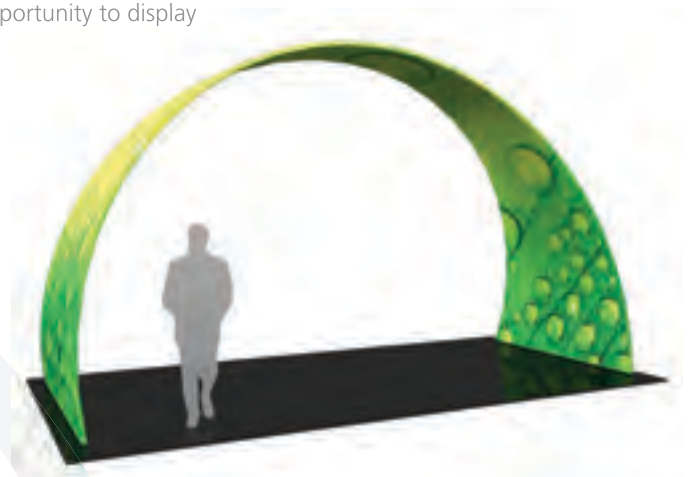

ARCH 03 20' ARCH-03

The Formulate™ Arch 03 is 11½ft tall and spans 19½ft wide. The Arch fits perfectly in a 20ft by 20ft island space. Shown in a 20' space.

FORMULATE CONFERENCE WALLS

Whether you are looking to create a semi-private meeting area within a tradeshow exhibit, special event, or in an interior environment, FORMulate™ tension fabric conference walls are lightweight, stylish solutions to your meeting space needs.

Ergonomically designed, Formulate C-shaped, Chip-shaped and Serpentine-shaped walls combine the latest developments in fabric printed technology with gently curved 50mm aluminum frames to create private, cozy and stylish conference areas within any space.



C-SHAPED WALL C-WALL

The Formulate™ C-Wall stands 8ft tall at its highest point and is 7ft 4in diameter. Perfect for a small table and chairs or benches for seating, this mini-conference area combines function and flare to create a stylish, semi-private space.

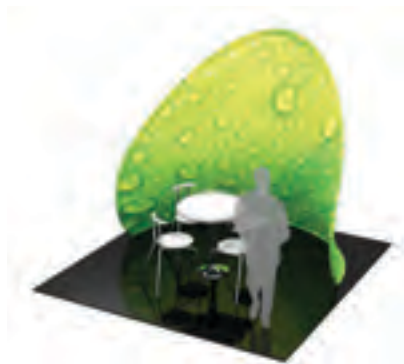

CHIP-SHAPED WALL CHIP-WALL

The Formulate™ Chip-Shaped Wall is a potato chip shaped structure that stands 8ft tall and is 9ft 3in wide. It is an ideal structure to create a semi-private conference/meeting area or projection wall within a space.

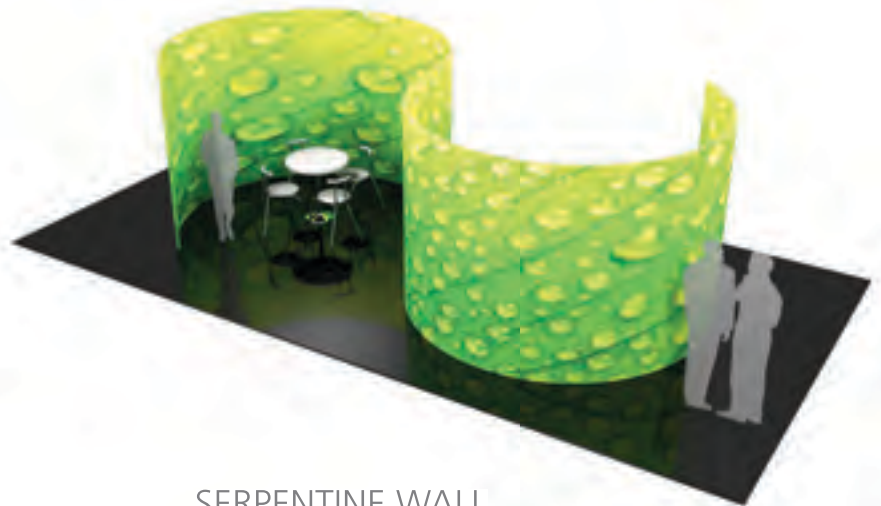

SERPENTINE WALL S-WALL

The Formulate™ Serpentine shaped wall connects two C-shaped structures to create a multipurpose, Serpentine shaped display. The Serpentine Wall is ideally used as a wall that separates two mini-conference and meeting areas. The Formulate Serpentine Wall is 7ft 8in tall and spans 22ft 10in wide – perfect for use in a large island space.

FORMULATE VIDEO WALLS & TABLET STANDS

Heavy-duty 50mm aluminum frames are coupled with stretch, zipper pillowcase fabric graphics to create flowing, uniquely-shaped Formulate™ curved walls and architectural structures that are ideal for tradeshow, events, corporate environments and interior spaces. With a variety of options, you can mix and match with other Formulate fabric structures to create the ideal display, booth or environment. Custom sizes also available.

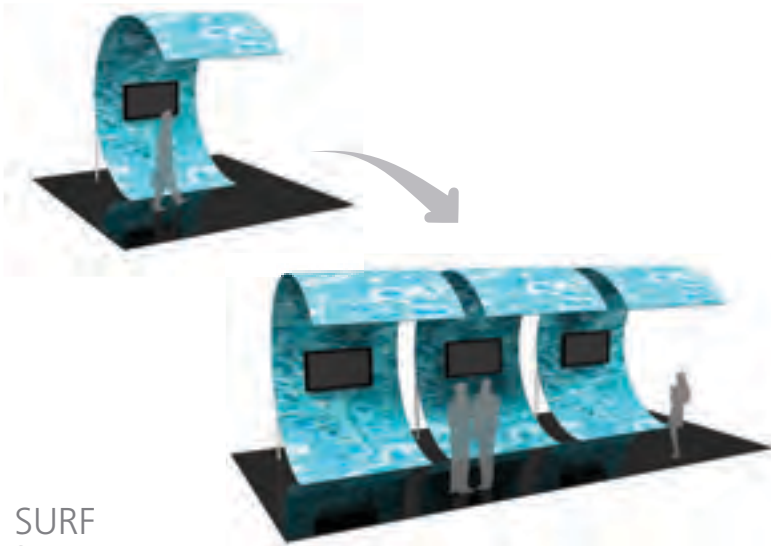

SURF
SURF-WALL

The Formulate™ Surf Wall is a C-shaped multimedia display that stands 11ft 5in tall with a width of 7ft 8in. With an organic, curved shape sustained by supporting legs, and a monitor mount for a monitor/TV, the Surf makes a distinctive statement in any space. Easily add more Surf Walls for an even bigger impact!

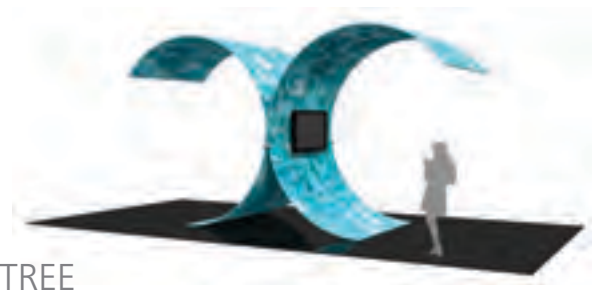

TREE
TREE

Two C-shaped structures are fused together to create a Tree shape with this sculptural, multimedia display. The Formulate™ Tree stands 11ft 5in tall and spans to 20ft 5in wide. The Formulate Tree includes two monitor mounts for use as a multimedia display.

TABLET STANDS

Are you looking to incorporate tablets into your display or environment? Sleekly-designed free standing tablet stands and kiosks make it easy to encourage interactivity, present information and engage your customers in any space.



TABLET KIOSK 01
TABLET-STD-01

33" w x 84.7" h x 23.73" d
Monitor mount, tablet holder
Pillowcase fabric graphic



TABLET KIOSK 02
TABLET-STD-02

20.2" w x 84.7" h x 23.73" d
Tablet holder
Pillowcase fabric graphic



TABLET KIOSK 03
TABLET-STD-03

20" w x 64" h x 15.19" d
Tablet holder
Pillowcase fabric graphic

FORMULATE FABRIC ROOMS & BANNERS

Formulate™ Fabric Rooms create a stylish and unique oasis for meetings, theater style presentations, graphic displays, demonstrations and much more. These rooms combine organic and architectural shapes with state-of-the-art zipper pillowcase dye-sublimated fabric graphics to create dynamic and functional meeting and display spaces. With so many options in the Formulate line of fabric structures and displays, it's easy to mix and match Formulate Rooms with other FORMulate accessories to create a truly customized look.



FLOWER
FLOWER-RM

The Formulate™ Flower creates a unique and dynamic space for meetings, demonstrations and more! It connects four C-shaped structures to FORMulate an organic and elegant floral shape. The structure is 28ft 4in square, 11ft 5in tall and fits ideally within a large island space.

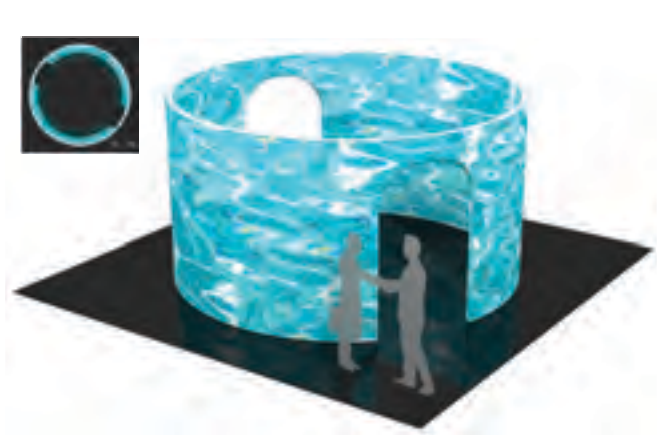

TREE HOUSE
TREEHOUSE-RM

The Formulate™ Tree House is a cylinder-shaped space perfect for meetings, graphical displays, projected presentations, a theater setting and much more. The Tree House is 15ft in diameter, 8ft tall and features two 7ft tall doorways, encouraging traffic flow through the structure.



SHARK FIN
SHARK

70" w x 86" h x 18" d
The Formulate™ Shark Fin is an ideal banner for any indoor or outdoor event. Simply slip the fabric graphic over the frame and you have an instant display.



FORMULATE FABRIC BANNER
FMLT-WV03-01

36" w x 91" h x 30" d
A sophisticated display for any space, the Formulate™ Vertical Curve fabric banner combines a lightweight aluminum frame with zipper-pillowcase graphic.



MEET.AND.GREET. TABLE THROWS & RUNNERS

One-stop-shop for the fastest table throws and runners • Can be used in many ways; perfect to display your messaging in any tradeshow or event – indoor or outdoor • Printed, imprinted, convertible, stretch and fitted options to choose from • Sizes of 6', 8', full and economy • Choose from 11 fabric colors and 21 vinyl colors

PRINTED TABLE THROW

- 4' full: TBL-T-4-F
- 4' economy: TBL-T-4-E
- 6' full: TBL-T-6-F
- 6' economy: TBL-T-6-E
- 8' full: TBL-T-8-F
- 8' economy: TBL-T-8-E

- complete your presentation with a premium printed table throw
- lends a polished appearance to any display
- maximize your advertising with additional space to display your message



shown with Horizon Standard tabletop folding panel display (page 107)



4' table throws available for smaller tables

carry bag available
(6 table throws)
TBL-THRW-BG



carry bag available
(4 table throws)
TBL-THRW-BG2



shown as 8' convertible table throw

CONVERTIBLE TABLE THROW

- convertible full: TBL-T-FC
- convertible economy: TBL-T-EC

- printed throw converts quickly and easily to fit both a 6' and 8' table
- Velcro tabs make conversion simple



shown as 6' converted table throw



All table throws and runners come with a graphic limited warranty of 6 months and are made in the USA

TABLE RUNNERS

- 24" full: TBL-R-24-F
- 24" economy: TBL-R-24-E
- 30" full: TBL-R-30-F
- 30" economy: TBL-R-30-E
- 60" full: TBL-R-60-F
- 60" economy: TBL-R-60-E

- accent your solid colored table throw with a full color printed runner
- available in 3 widths



FITTED TABLE THROW

- 6' full: TBL-FT-6-F
- 8' full: TBL-FT-8-F



- form fitted to fit 6' & 8' tabletops
- optional carry bag available
- fitted fabric dye-sublimated printed table throw lends a polished look to any display



STRETCH TABLE THROW

- 6' full: TBL-SW-6-F
- 8' full: TBL-SW-8-F



- tailored to fit 6' & 8' tables top to bottom
- optional carry bag available
- stretch fabric dye-sublimated printed table throw lends a stylish look to any display



All table throws and runners come with a graphic limited warranty of 6 months and are made in the USA

IMPRINTED TABLE THROW

- 6' full
- 6' economy
- 8' full
- 8' economy

- 11 standard table throw colors
- maximum logo size = 60" w x 21.5" h (see template for details)
- must be simple vector artwork, no complex logos or gradients
- referenced Pantone colors are not exact



full table throw shown in purple fabric with white and sky blue imprinted vinyl



economy table throw leaves back of table exposed for easy access to storage

FULL TABLE THROW



ECONOMY TABLE THROW

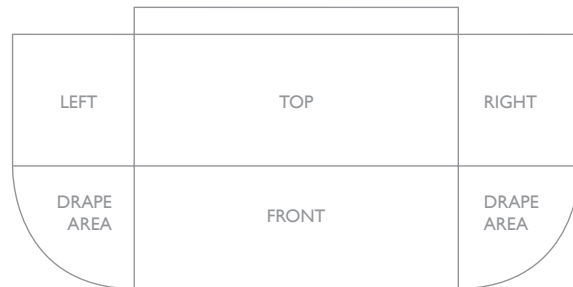

FABRIC COLORS

red Pantone® 201C	royal blue Pantone® 661C	purple Pantone® Violet C	yellow Pantone® 1235C
beige Pantone® 728C	burgundy Pantone® 504C	gray Pantone® 422C	hunter green Pantone® 350C
navy Pantone® 282C	black	white	

VINYL COLORS

black	white	blue Pantone® 293C	hot pink Pantone® Process Magenta C	royal purple Pantone® 2755C	red Pantone® 200C	vegas gold Pantone® 467C
kelly green Pantone® 342C	sky blue Pantone® 283C	lemon yellow Pantone® 101C	medium yellow Pantone® 123C	burnt orange Pantone® 167C	orange Pantone® 021C	gray Pantone® Cool Gray 9C
navy Pantone® 2766C	apple green Pantone® 368C	forest green Pantone® 350C	vanilla cream Pantone® 7499C	sapphire blue Pantone® 2925C	brown Pantone® 1545C	teal Pantone® 315C



All table throws and runners come with a graphic limited warranty of 6 months and are made in the USA



CREATE.ATTRACT.ENGAGE. **ORBITAL EXPRESS™ TRUSS**

The Orbital Express™ System is quite possibly the easiest Truss • This system has a set number of parts and connectors and requires NO TOOLS for assembly • This versatile system enables you to reconfigure a kit in multiple ways and combinations using the same parts • With Orbital, you can have the impact of a “new look” for every show



FIVE YEAR

ORBITAL EXPRESS™ TRUSS

The Orbital Express Truss™ System requires NO TOOLS for set up! Installation couldn't be easier; simply twist & lock. The specially designed connectors are simple to use, strong & secure. Our truss kits can be reconfigured in multiple ways using the same parts. Have a different exhibit for each show! We offer more than 60 professionally designed "off the shelf" kits for a variety of booth sizes and configurations.

ORBITAL EXPRESS | 10' X 10' KITS

PLANETARY



SIRIUS
10'x10'
KIT OR-K-SR1



ORBITAL EXPRESS™ TRUSS HERCULES KITS

The Hercules line of Orbital Express™ Truss features basic backwalls and kits in a variety of sizes to suit a range of space needs. A benefit to this versatile system is that it enables you to reconfigure kits in multiple ways and combinations using the same parts. Simply add or detract from any Hercules kit to create a new appearance for every event or tradeshow!

ORBITAL EXPRESS | 10' X 10' KITS

HERCULES



HERCULES 01

10'x10' KIT OR-K-HC01

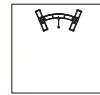

HERCULES 02

10'x10' KIT OR-K-HC02



HERCULES 03

10'x10' KIT OR-K-HC03

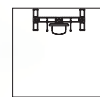

HERCULES 04

10'x10' KIT OR-K-HC04

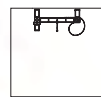

HERCULES 05

10'x10' KIT OR-K-HC05

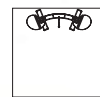

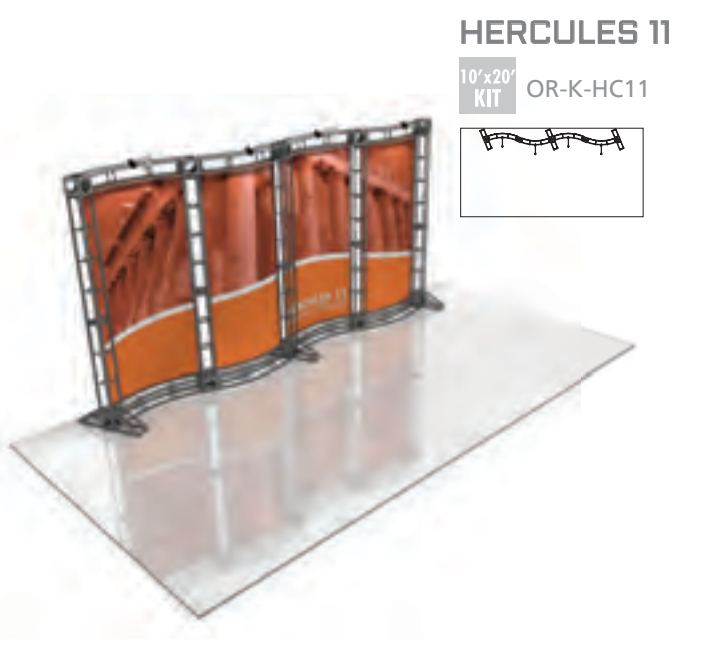
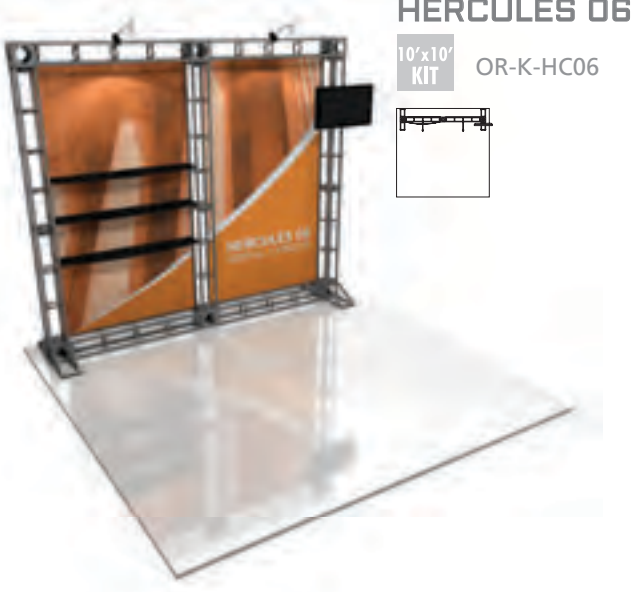

HERCULES 12

10'x20'
KIT

OR-K-HC12

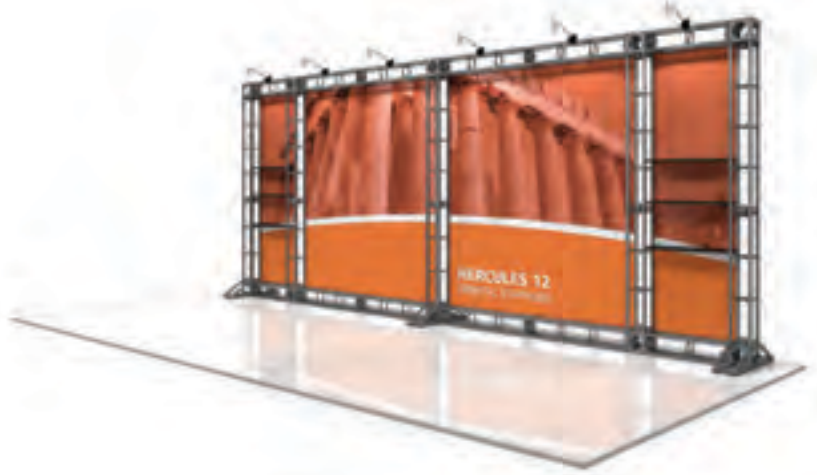
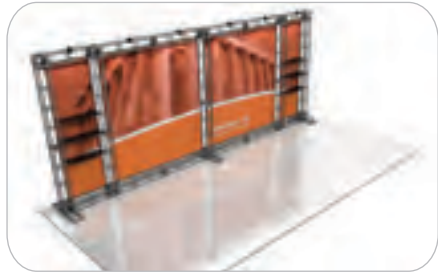
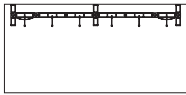

HERCULES 13

10'x20'
KIT

OR-K-HC13

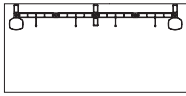

HERCULES 14

10'x20'
KIT

OR-K-HC14

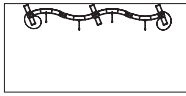

HERCULES 15

10'x20'
KIT

OR-K-HC15

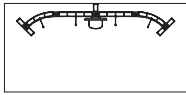

ORBITAL EXPRESS™ TRUSS PLANETARY KITS

The Planetary line of Orbital Express™ Truss features over 40 professionally designed “off the shelf” kits for a variety of booth sizes and configurations. Each kit comes complete with all the parts, fixtures and fittings you need to create a successful exhibit, including (depending on the kit) low voltage spotlights and adjustable tabletops. A benefit to this versatile system is that it enables you to reconfigure kits in multiple ways and combinations using the same parts. Orbital Express Truss can also be easily customized!

VELA-2

10'x10' KIT OR-K-VL1-2



backwall height = 72.5"

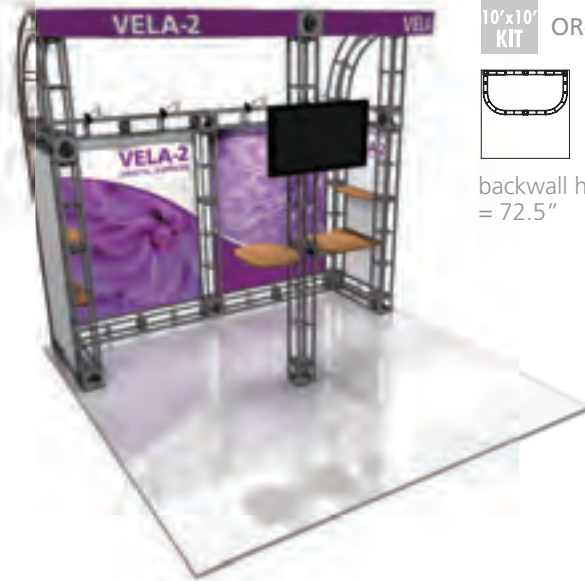

CETUS

10'x10' KIT OR-K-CT1

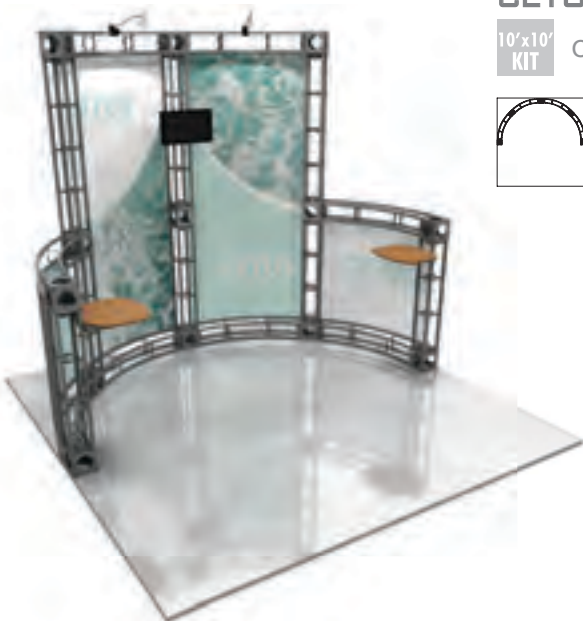

LYRA

10'x10' KIT OR-K-LY1 corner kit

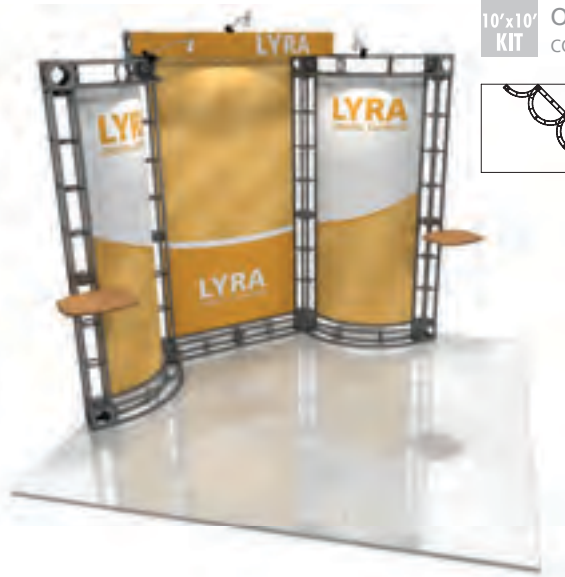

CARINA

10'x10' KIT OR-K-CR1

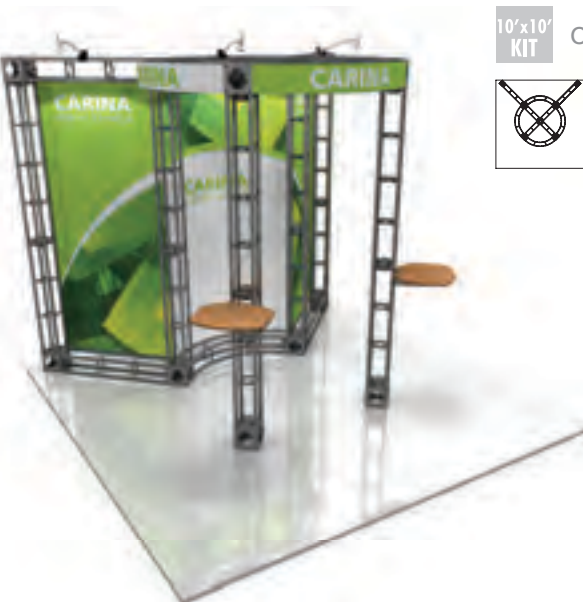

CASTOR

10'x10' KIT OR-K-CS1

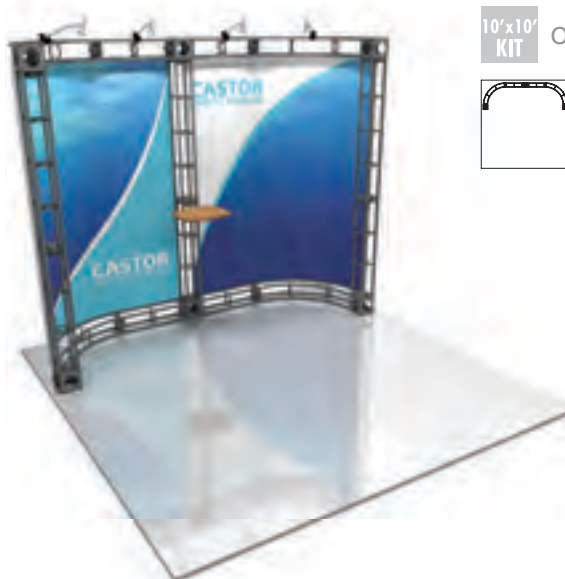



CYGNUS
10'x10' KIT OR-K-SYG2
corner kit

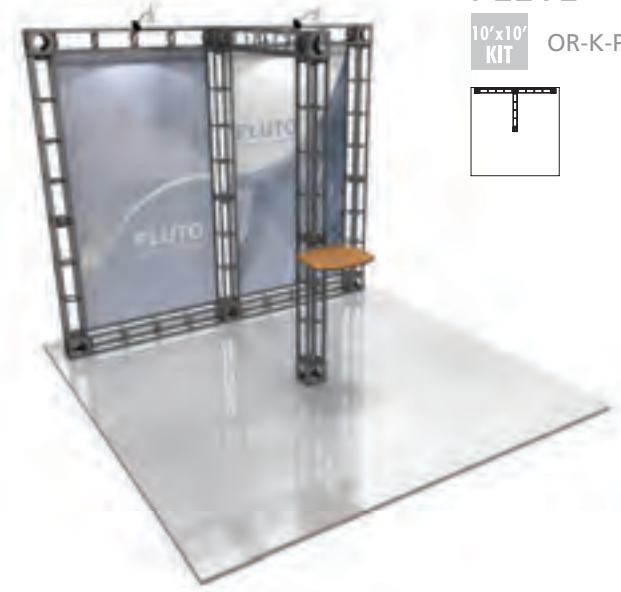
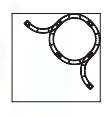

PLUTO
10'x10' KIT OR-K-PL1

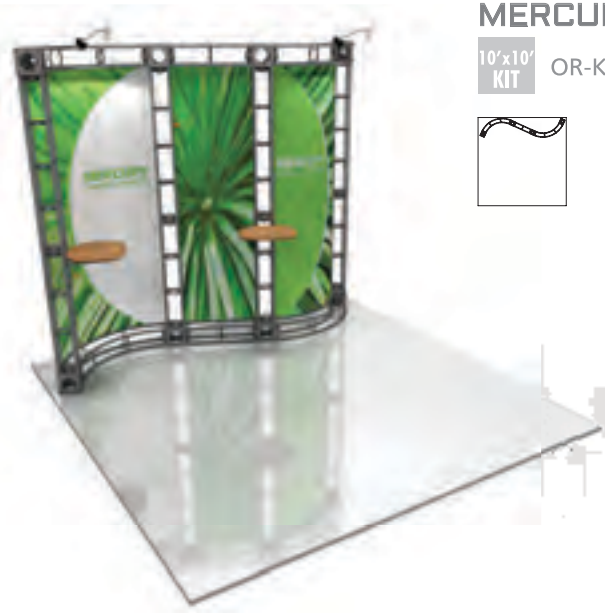
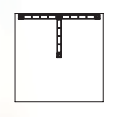

MERCURY
10'x10' KIT OR-K-ME1

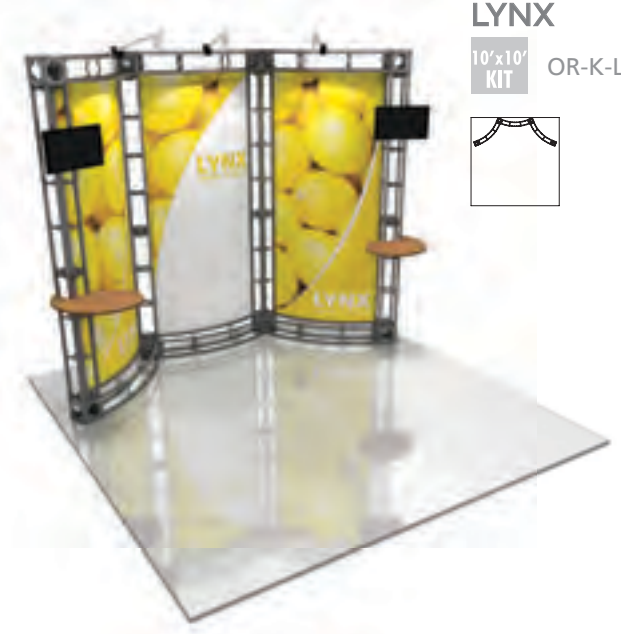
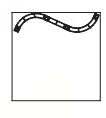

LYNX
10'x10' KIT OR-K-LX1

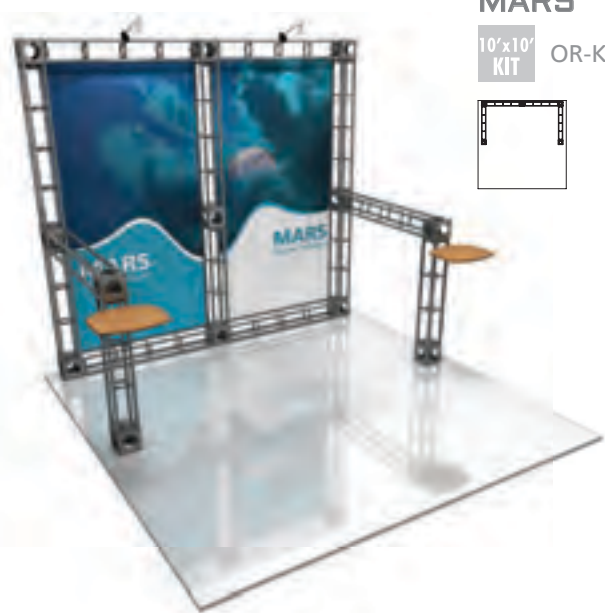

MARS
10'x10' KIT OR-K-MR1



ARA
10'x10' KIT OR-K-AA1

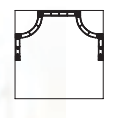

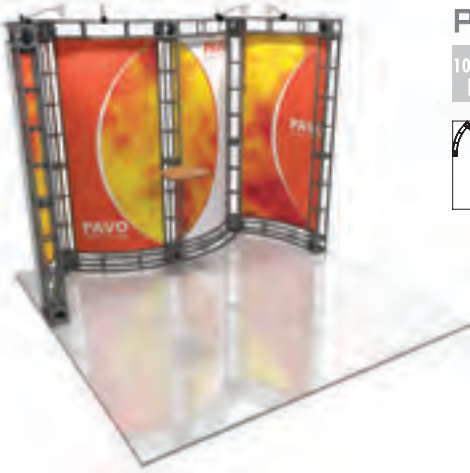

PAVO
10'x10'
KIT OR-K-PA1

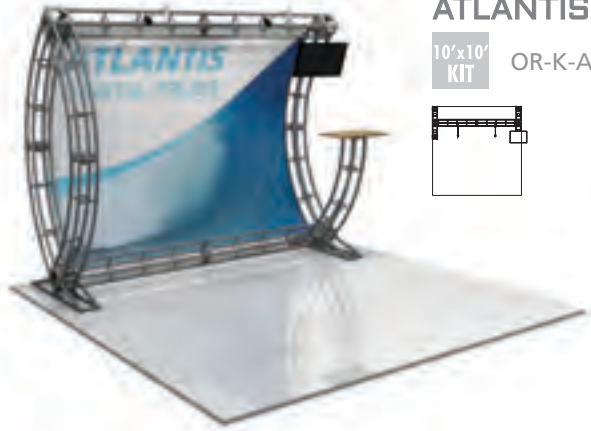

ATLANTIS
10'x10'
KIT OR-K-ATL3

CEPHEUS-2

10'x20'
KIT OR-K-CE1-2

backwall height = 72.5"

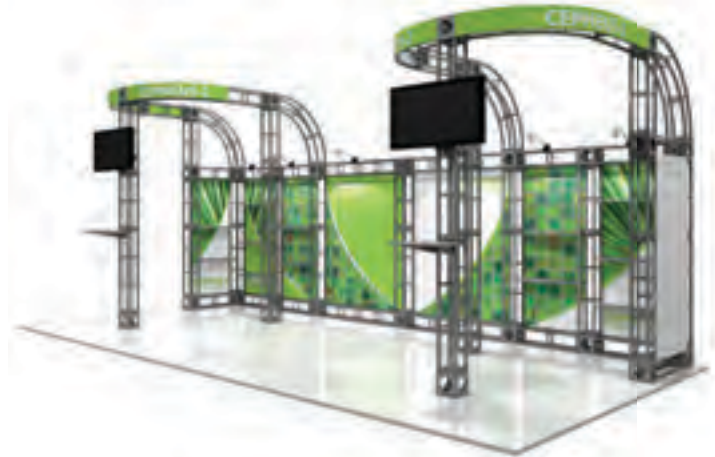
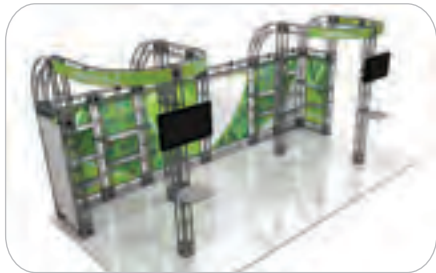
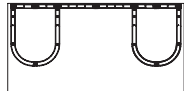

THETA

10'x20'
KIT OR-K-TH1

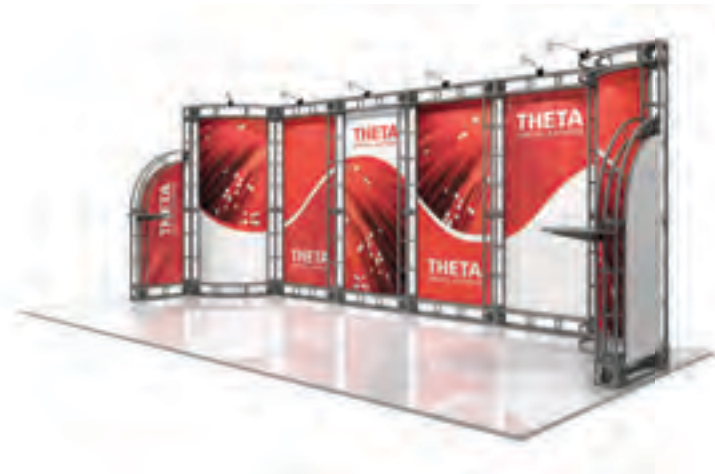

PICTOR

10'x20'
KIT OR-K-PC1

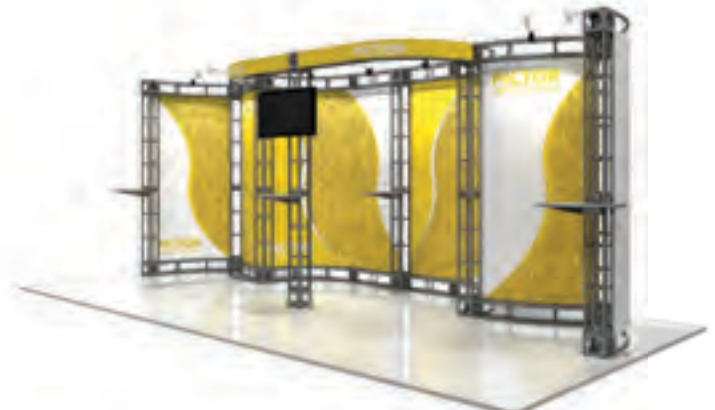
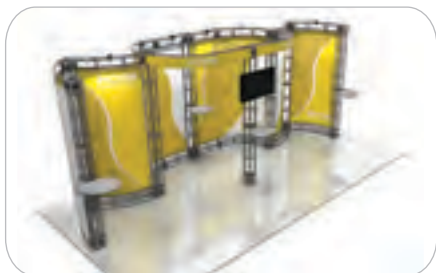
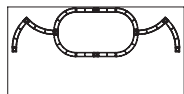

INDUS

10'x20'
KIT OR-K-IN1

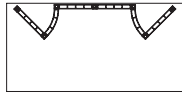

ANTARES

10'x20'
KIT OR-K-AT1

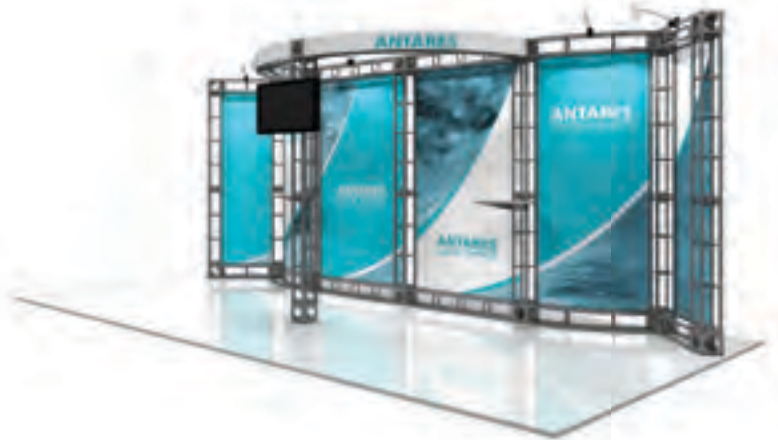
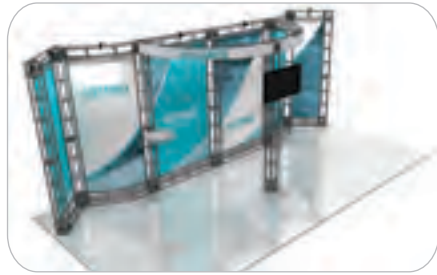
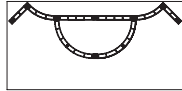

SATURN

10'x20'
KIT OR-K-SA1

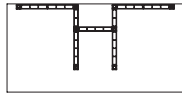

ELECTRA

10'x20'
KIT OR-K-EL1

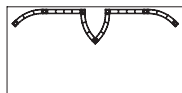

PHOENIX

10'x20'
KIT OR-K-PX1

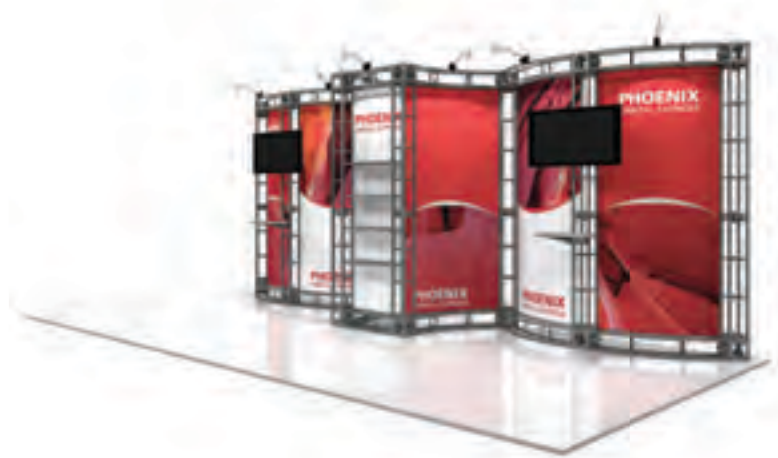
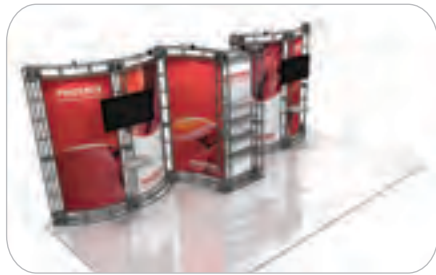
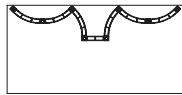

POLARIS

10'x20'
KIT OR-K-PR1

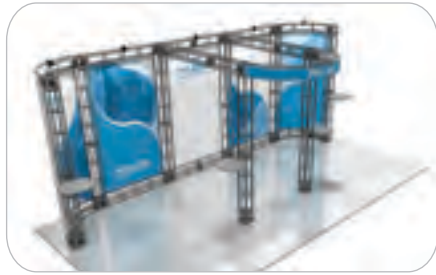
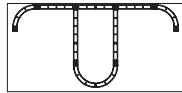

OMICRON

10'x20'
KIT OR-K-OM1

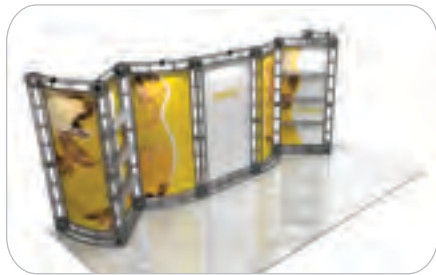

ANDROMEDA

10'x20'
KIT OR-K-AD1

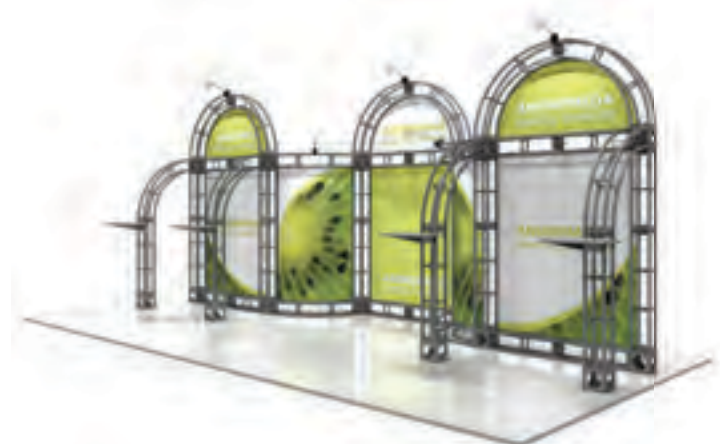
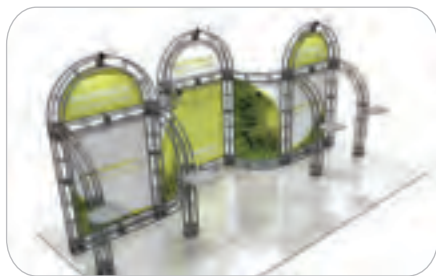
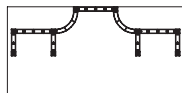

ARCTURUS

10' x 20'
KIT OR-K-AR1

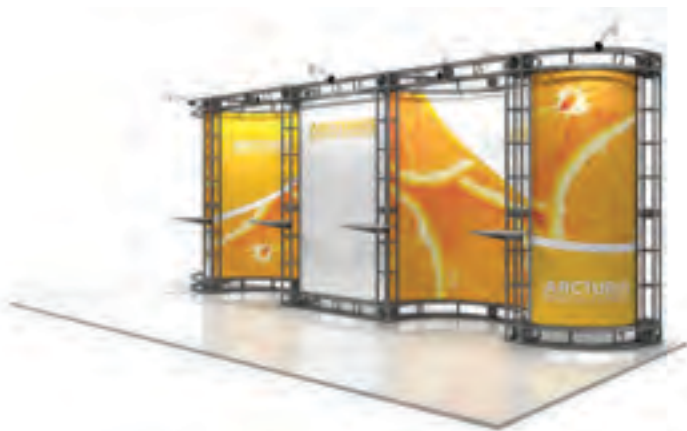
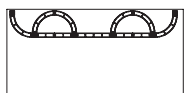

VENUS

10' x 20'
KIT OR-K-VE1

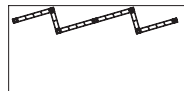

MAGELLAN

10' x 20'
KIT OR-K-MG1

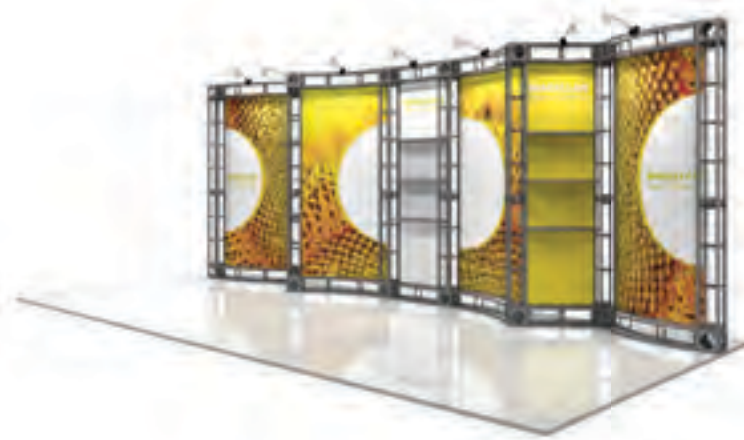
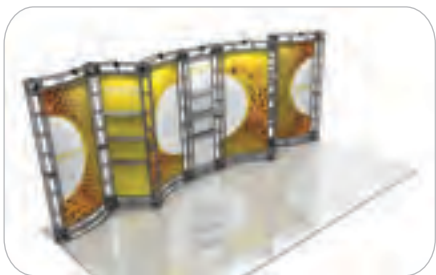
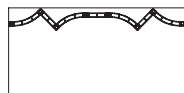

HYDRUS

10' x 20'
KIT OR-K-HD1

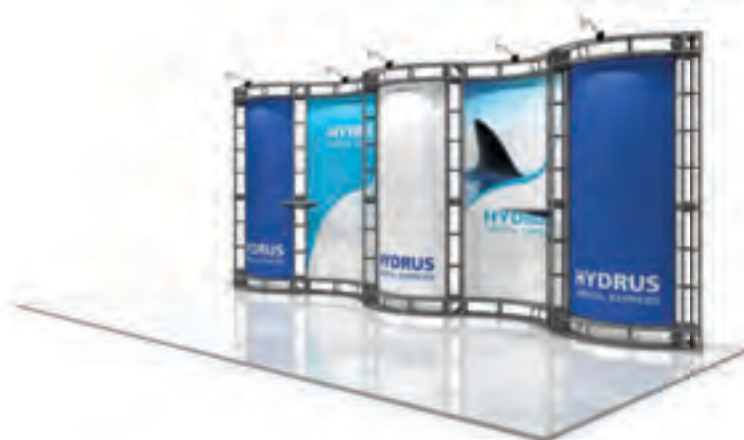
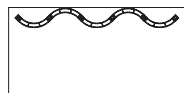

LEO

20'x20'
KIT

OR-K-LE1

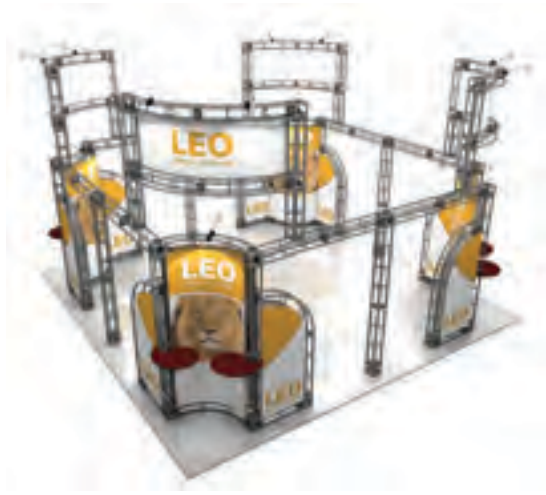
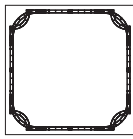

DORADO

20'x20'
KIT

OR-K-DO1

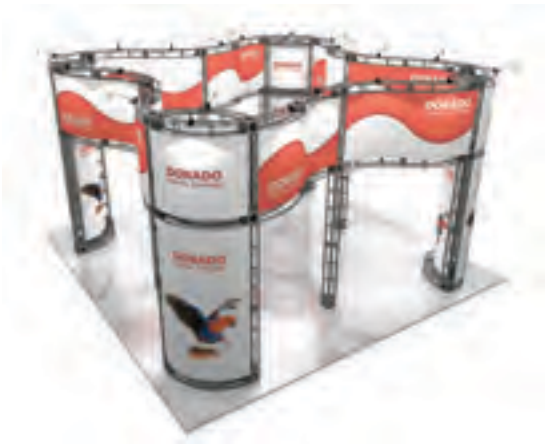
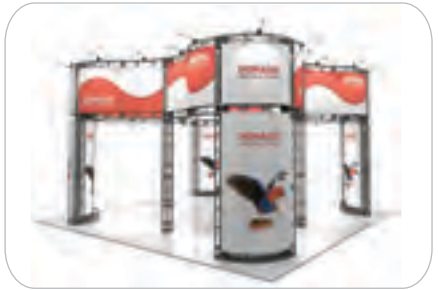
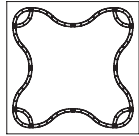

CORVUS

20'x20'
KIT

OR-K-CV1

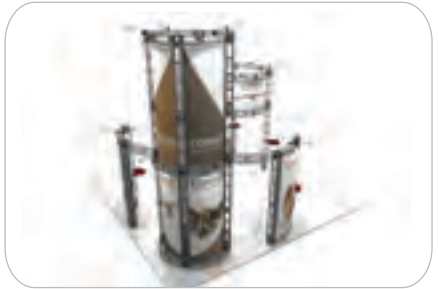
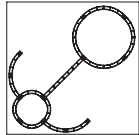

CENTAURUS

20'x20'
KIT

OR-K-CN1

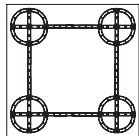

NEPTUNE

20'x20'
KIT OR-K-NP1

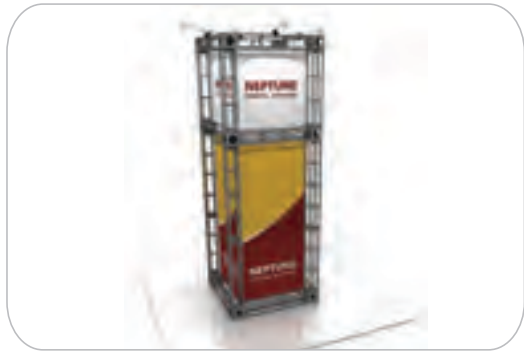
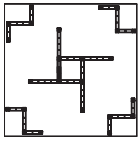

tower also sold separately: OR-K-NET

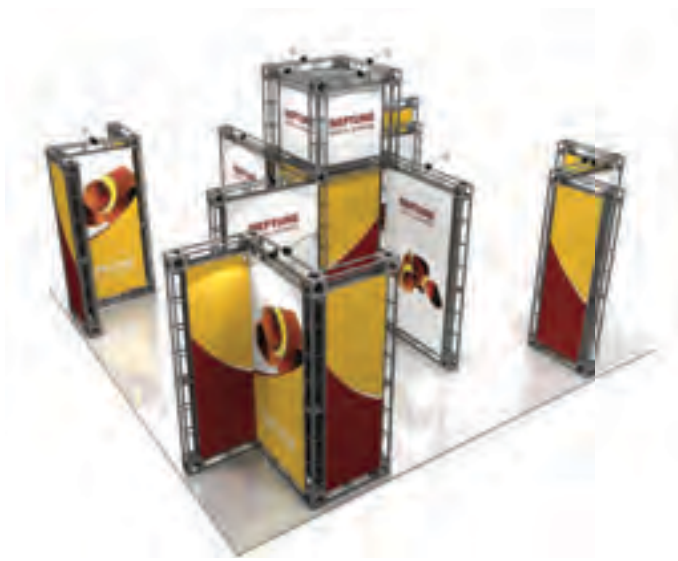

TUCANA

20'x20'
KIT OR-K-TU1

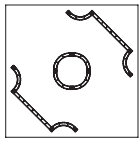

tower also sold separately: OR-K-TUT

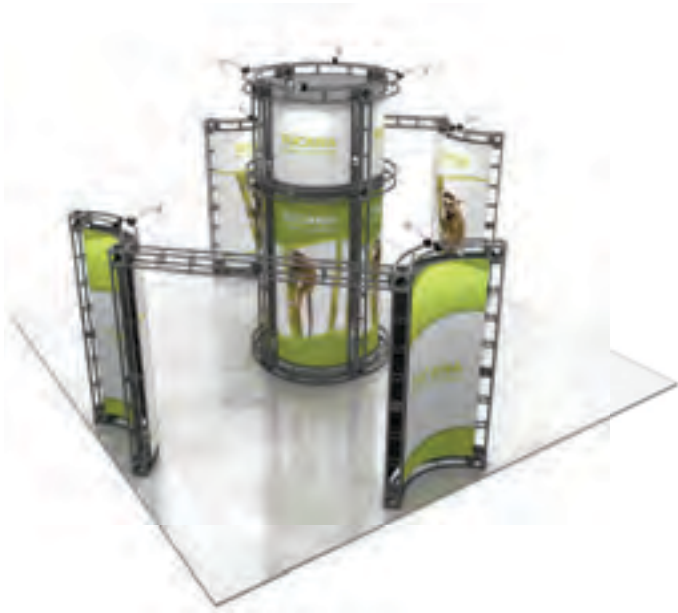

ORION

20'x20'
KIT OR-K-OR1

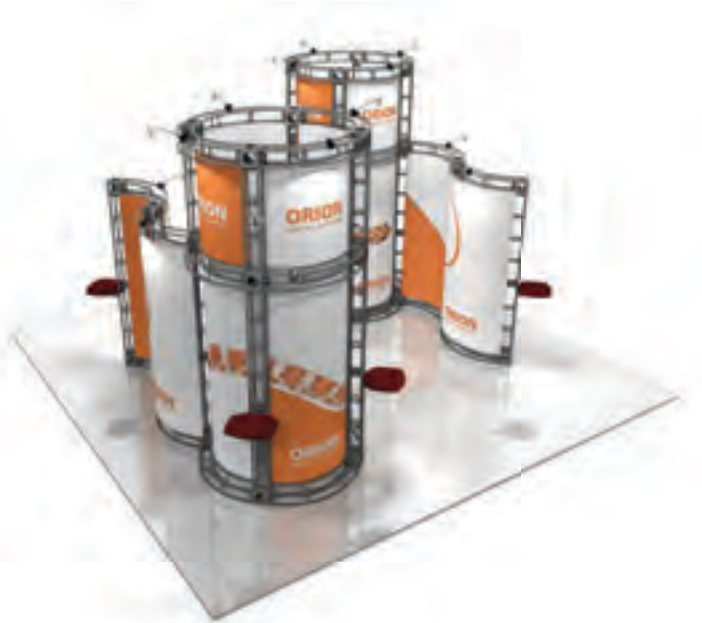
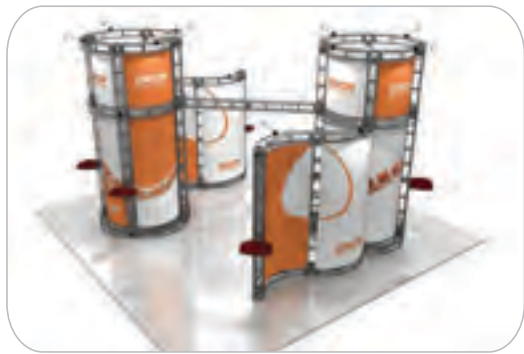
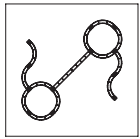

VEGA

20'x20'
KIT OR-K-VG1

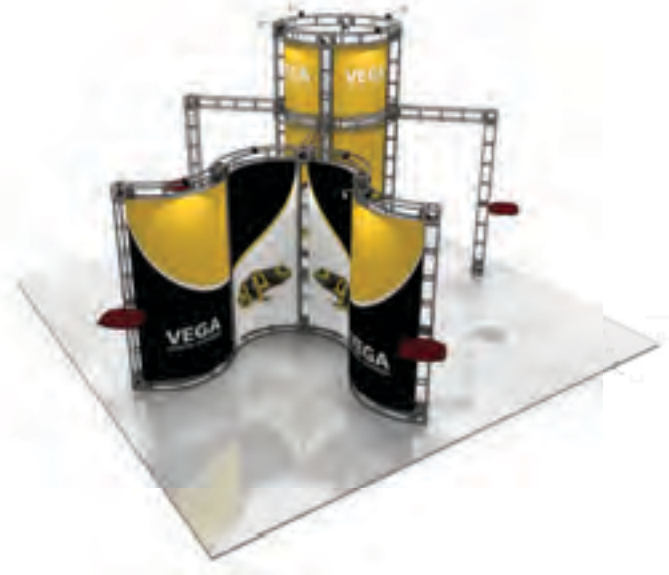
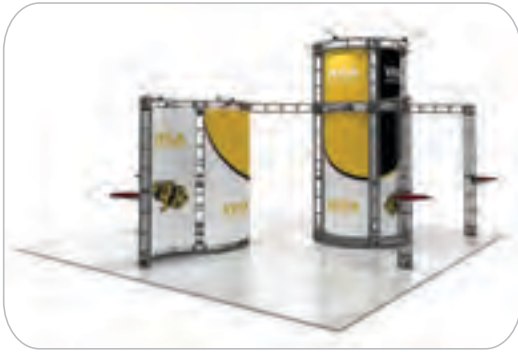
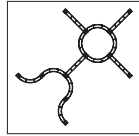

ALTAIR

20'x20'
KIT OR-K-AL1

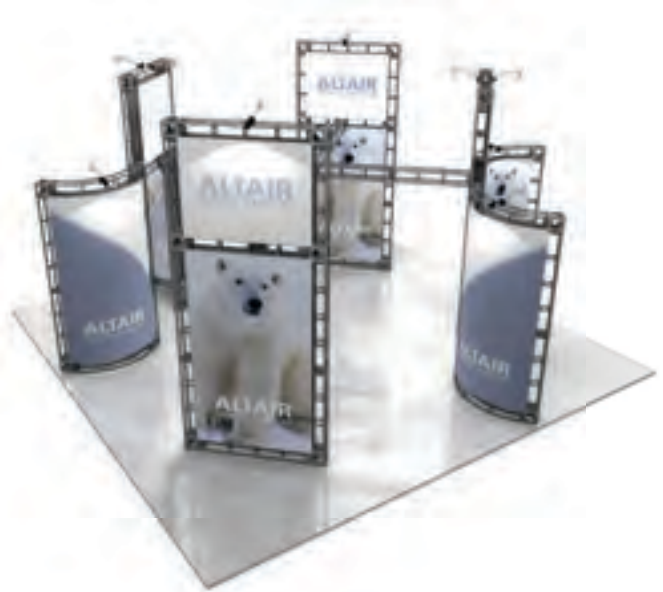
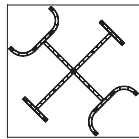

CANIS

20'x20'
KIT OR-K-CA1

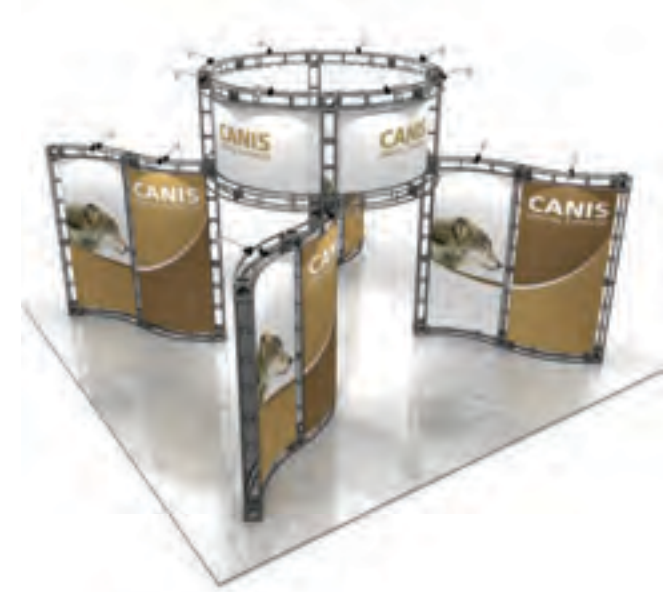
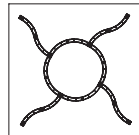

DRACO

20'x20'
KIT OR-K-DR1

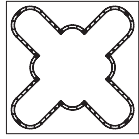

JUPITER

20'x20'
KIT OR-K-JP1

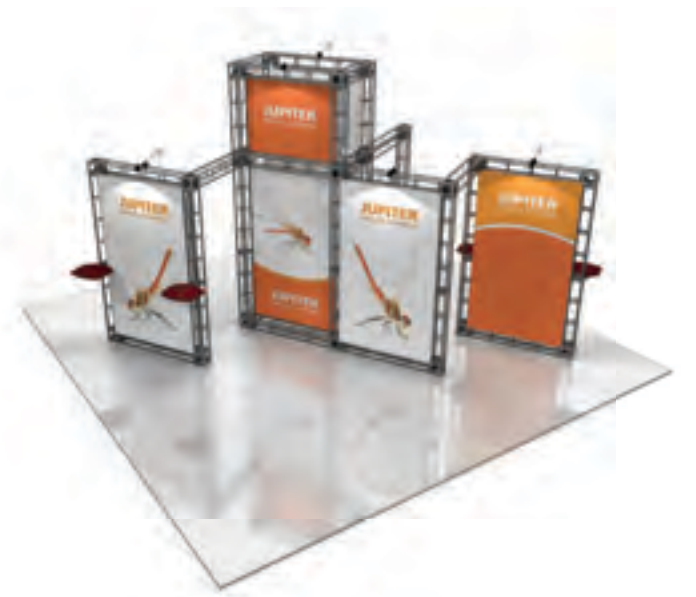
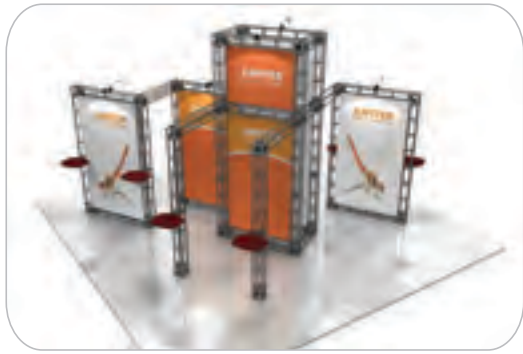
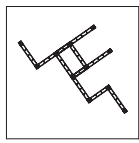

CASSIOPEIA

20'x20'
KIT OR-K-CP1

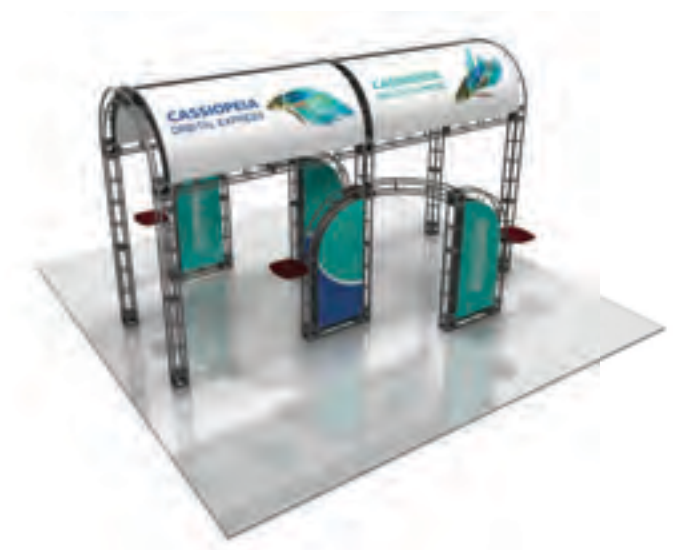
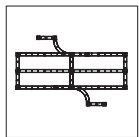

ORBITAL TRUSS COUNTERS & ACCESSORIES



Truss counter tops are available in your choice of four thermoform finishes

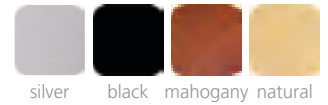

Truss Counters & Podiums have several attractive designs to choose from with a sleek plex top as an available option. Choose from 4 tabletop colors. Graphic options are also available for Truss Counters. No tools needed for assembly.



RECTANGLE
standard: OR-TC01
with plex stand-off and internal shelf: OR-TC01-P



OVAL
standard: OR-TC02
with plex stand-off and internal shelf: OR-TC02-P



RACETRACK
standard: OR-TC03
with plex stand-off and internal shelf: OR-TC03-P



CURVE
standard: OR-TC04
with plex stand-off and internal shelf: OR-TC04-P



CIRCLE
standard: OR-P01
with plex stand-off: OR-P01-P



TEARDROP
standard: OR-P02
with plex stand-off: OR-P02-P



EYE
standard: OR-P03
with plex stand-off: OR-P03-P



RACETRACK
standard: OR-P04
with plex stand-off: OR-P04-P



SQUARE
standard: OR-P05
with plex stand-off: OR-P05-P

LAMINATE TABLETOPS

NATURAL



standard: OR-TBL-WD
right facing: OR-TBL2-R-WD
left facing: OR-TBL-L-WD

MAHOGANY



standard: OR-TBL-DWD
right facing: OR-TBL2-R-DWD
left facing: OR-TBL2-L-DWD

SILVER



standard: OR-TBL-S
right facing: OR-TBL2-R-S
left facing: OR-TBL2-L-S

BLACK



standard: OR-TBL-B
right facing: OR-TBL2-R-B
left facing: OR-TBL2-L-B



INTERNAL SHELVING

- available in all 4 finishes
- 24" straight span, 36" straight span, and 46" straight span shelves available
- 45° curved and 90° curved shelves

LIT RACK

OR-STG

- 10 pocket clamp on literature rack
- note: rack may not fit into the standard kit packaging solution/ molded case



OPTI MOUNTS



OPTI-MOUNT 1
OR-LCD1-B
13"- 27" LCD
max weight = 50 lbs



OPTI-MOUNT 2
OR-LCD2-B
26"- 42" LCD
max weight = 100 lbs



OPTI-MOUNT 3
OR-LCD3-B
32"- 70" LCD
max weight = 150 lbs



All Orbital Truss accessories come with a five year warranty.



ELEGANT.INTELLEGENENT.DRAMATIC. **LINEAR™ DISPLAY SYSTEMS**

Linear™ 10ft and 20ft display systems couple heavy-duty extrusion-based frames with Velcro-applied fabric graphics to create a customized look • Provides the benefit of an off-the-shelf solution with a custom appearance • Headers, wings, table accents, literature racks, monitor mounts and counters are just some of the Linear line features that can make a Linear exhibit unique



LINEAR™ TABLETOPS

Linear™ Tabletop Kits provide modern and dynamic flare to your marketing message. The silicone edge graphics (SEG) and extrusion-based displays are simple, lightweight and take minutes to assemble. Units come in a sturdy case. Customized units also available.



5' tabletop
footprint dimensions:
57" w x 31.5" h x 17.72" d
LN-K-TT-01



5' tabletop
footprint dimensions:
61.5" w x 31.5" h x 17.72" d
LN-K-TT-02



4½' tabletop
footprint dimensions:
53.93" w x 39.37" h x 17.72" d
LN-K-TT-03



8' tabletop
footprint dimensions:
96" w x 39.37" h x 17.72" d
LN-K-TT-04



Linear Tabletop kits come with easy-to-apply silicone edge graphics (SEG) as well as multiple accessories.

LINEAR™ STANDARD

Linear™ Standard Kits provide a modern, slick and stylish appearance. The extrusion based exhibits feature **velcro-applied fabric graphics**. Headers and wings available in UV printed graphics or frosted plex. Kits come with two lights and ship in durable storage cases. Options include LCD monitor mounts, tables, counters, literature pockets and larger freight cases. Customized units also available.



LINEAR STANDARD



STANDARD 01

10'x10'
KIT LN-K-3P-01



STANDARD 02

10'x10'
KIT LN-K-3P-02



STANDARD 03

10'x10'
KIT LN-K-3P-03



STANDARD 05

10'x10'
KIT LN-K-3P-05



STANDARD 12

10'x20'
KIT LN-K-3P-12



STANDARD 14

10'x20'
KIT LN-K-3P-14



STANDARD 16

10'x20'
KIT LN-K-3P-16



STANDARD 18

10'x20'
KIT LN-K-3P-18



LINEAR™ PRO

Linear™ Pro Kits provide a modern, slick and stylish appearance. The extrusion based exhibits feature **velcro-applied fabric graphics**. Headers and wings available in UV printed graphics or frosted plex. Kits come with a fabric graphic canopy, two lights and ship in durable storage cases. Options include LCD monitor mounts, tables, counters, literature pockets and larger freight cases. Customized units also available.



PRO 22

10'x10'
KIT LN-K-3P-22



PRO 25

10'x10'
KIT LN-K-3P-25



PRO 26

10'x20'
KIT LN-K-3P-26



PRO 27

10'x20'
KIT LN-K-3P-27



LINEAR™ COUNTER

LN-TBL-SA-RCT

- coordinates with the Linear hybrid modular display line
- 3 graphic panels available to display your custom graphics
- quick & easy to assemble, tool included
- fits in an OCH shipping and transport case
- aluminum design is sturdy and stable
- available in all four laminate finishes (page 98)

LINEAR™ BOLD

Linear™ Bold Kits command attention with a heavy-duty aluminum structure and functional, yet stylish features. These hybrid modular displays feature center panel, side and accent headers, tables and lights and ship in durable storage cases. Options include LCD monitor mounts, tables, counters, literature pockets and larger freight cases. Customized units also available.



LINEAR BOLD



BOLD 31
10'x10' KIT LN-K-31

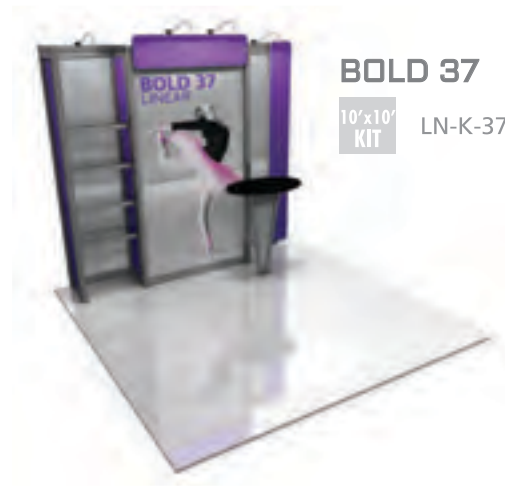

BOLD 37
10'x10' KIT LN-K-37



BOLD 32
10'x20' KIT LN-K-32



BOLD 38
10'x20' KIT LN-K-38

LINEAR ACCESSORIES



Literature Pocket LN112



Monitor Bracket 1 LN-LCD1-B
13" - 27" LCD
max weight = 50 lbs



Monitor Bracket 2 LN-LCD2-B
26" - 42" LCD
max weight = 100 lbs



LINEAR™ BOLD COUNTERS

Dress up your space with sophisticated and functional counters. Counter tops are available in four thermoform finishes – silver, black, mahogany and natural. Printed graphic panels create the base of the counter. Comes standard with locking cabinet door. Custom counter top colors are available.

LINEAR BOLD COUNTERS



LN-CU-01



LN-CU-02



LN-CU-03



LN-CU-05



LN-CU-06



LN-CU-07

Linear counter tops are available in your choice of four thermoform finishes

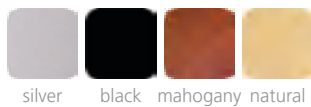

silver black mahogany natural



LN-CU-08



VIBRANT.VERSATILE.VISION. VECTOR FRAME™ TENSION FABRIC

Vector Frame™ backwalls and kits can configure from a banner to a backwall to a full exhibit • Quality crafted and manufactured in the USA, Vector Frame is customizable, reconfigurable and with simple graphic changes • Convey new or multiple messages easily • Single and double-sided fabric graphic options make it easy to get a maximum impact

VECTOR FRAME™ KITS

Stand apart from the competition with a clean, sophisticated 10'x10' or 10'x 20' Vector Frame™ exhibit kit. The Vector Frame series is a collection of extrusion-based, dye-sublimated fabric mural graphic displays. Vector Frame exhibits are easy to assemble and disassemble.



Vector Frame counter tops are available in your choice of four thermoform finishes

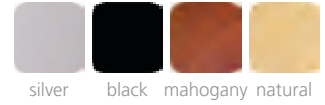

silver black mahogany natural



OCH2
wheeled molded
cases included
with each kit
(page 119)



VECTOR FRAME™ COUNTER VFC-01

- 39.37" w x 36.62" h x 22.5" d
- four locking Vector Frames
- fabric graphics for four sides
- tops available in four finishes
- comes in 1 OCH2 case

VECTOR FRAME™ BANNERS

Vector Frame™ banners combine aluminum extrusion frames with tension fabric mural graphics to create a versatile banner, backwall, hanging art or display. Vector Frame banners can be used to display messaging or art in a corporate environment or at a tradeshow.



05 Rectangle
VF-R-05
118" w x 94" h x 19" d
comes in 1 OCL case

fits perfect in a 10' space

AVAILABLE SIZES



01 Rectangle
VF-R-01
35" w x 47" h x 13" d
comes in 1 OCL case



02 Rectangle
VF-R-02
35" w x 70" h x 13" d
comes in 1 OCS case



03 Rectangle
VF-R-03
47" w x 70" h x 19" d
comes in 1 OCL case



04 Rectangle
VF-R-04
47" w x 94" h x 19" d
comes in 1 OCL case



01 Square
VF-S-01
35" w x 35" h x 13" d
comes in 1 OCS case



02 Square
VF-S-02
47" w x 47" h x 13" d
comes in 1 OCL case



03 Square
VF-S-03
70" w x 70" h x 19" d
comes in 1 OCS case



04 Square
VF-S-04
94" w x 94" h x 19" d
comes in 1 OCL case



VECTOR FRAME™ WALL BRACKET VF-BRKT-4

- supports any size vector frame
- quick and easy to assemble
- turns your vector frame from a portable to a wall display
- customer to provide fasteners
- sold in packs of four



OCS

OCL



KIT 01
10'x10'
KIT VF-K-01



KIT 02
10'x10'
KIT VF-K-02



KIT 03
10'x10'
KIT VF-K-03



KIT 04
10'x10'
KIT VF-K-04

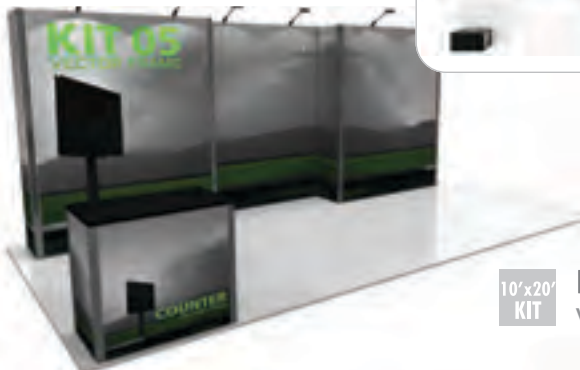

KIT 05
10'x20'
KIT VF-K-05

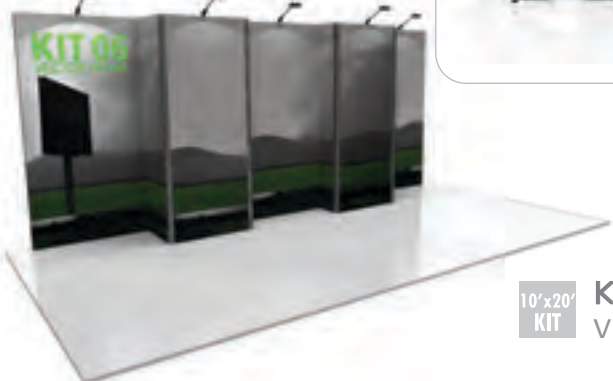

KIT 06
10'x20'
KIT VF-K-06

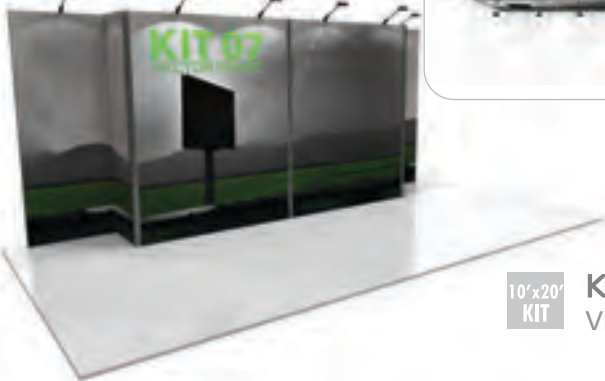

KIT 07
10'x20'
KIT VF-K-07

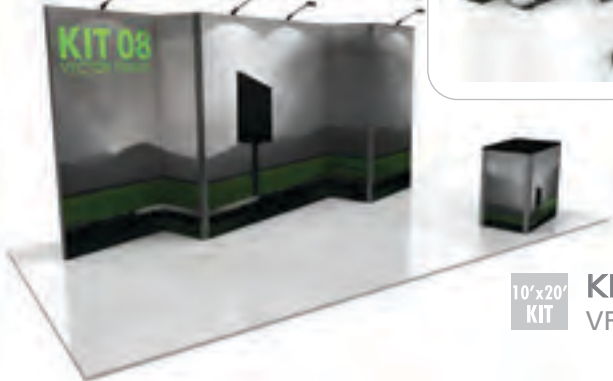

KIT 08
10'x20'
KIT VF-K-08



ADAPTABLE.FUNCTIONAL.PERFORMANCE. **FOLDING DISPLAY PANELS**

Premium portable folding panels provide a professional appearance without the fuss • Our variety of portable folding panels are superbly crafted with seamless panels made of ultra-light core material • Covered on both sides with polyester fabric, which come in a plethora of color choices and options • Use the Velcro-friendly panels as a way to feature your message or add optional detachable graphics

HERO™ DISPLAY PANELS

Hero™ panel displays are durable premium exhibit panel kits that feature the convenience of folding panels with elegant, seamless panel construction. Hero kits are available in a variety of fabric colors and feature concealed hinges with unique 2" radius curved ends to lend a polished appearance.



fits in an OCH case (case not included, see page 119)



shown with optional graphics
HERO H16

3'11" HIGH

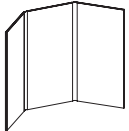

HERO H02-1
tabletop display

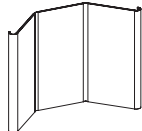

HERO H02-2
tabletop display with curved end caps



HERO H03
tabletop display with backlit header



HERO H04
tabletop display with backlit header and curved end caps

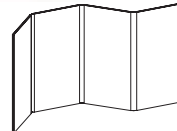

HERO H05
tabletop display

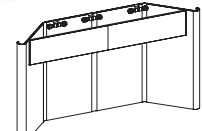

HERO H08
tabletop display with backlit header and curved end caps

7'10" HIGH

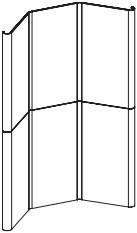

HERO H09
full height exhibit with curved end caps

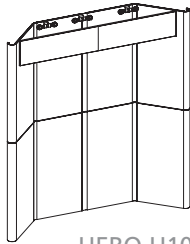

HERO H10
full height exhibit with curved end caps and backlit header

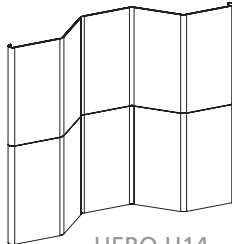

HERO H14
full height exhibit with curved end caps

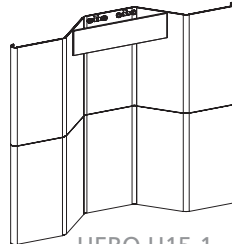

HERO H15-1
full height exhibit with curved end caps & backlit header

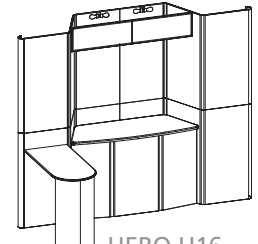

HERO H16
10' full height exhibit kit with curved end caps, backlit header & peninsula

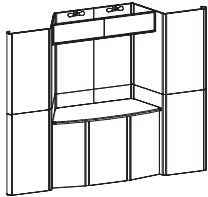

HERO H17
10' full height exhibit kit with curved end caps & backlit header

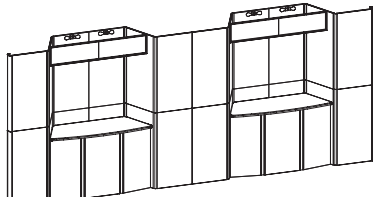

HERO H18
20' full height exhibit kit with curved end caps & backlit header

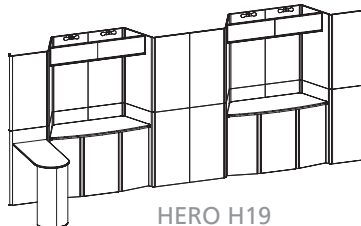

HERO H19
20' full height exhibit kit with curved end caps, backlit header & one peninsula

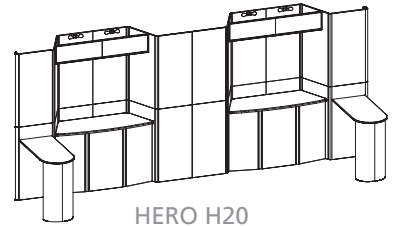

HERO H20
20' full height exhibit kit with curved end caps, backlit header & two peninsulas

FABRIC CHOICES

All Horizon & Hero display systems are available with printed graphic murals or "velcro-friendly" fabric panels of your choice. Actual fabric color may vary slightly.

regal - smooth exhibit & display fabric

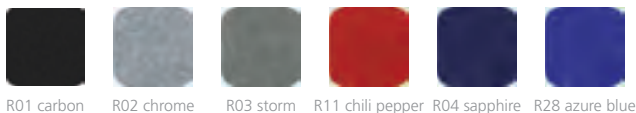

premier - ribbed exhibit & display fabric



VOYAGER™ FOLDING PANELS

The Voyager™ has been specially developed as a briefcase style tabletop display and is a great choice for promotions on the go. It has a rigid, thermo formed ABS exterior and a black, Velcro compatible fabric interior. Detachable graphics allow for easy message changes! Headers shown are an additional option. Extra graphics can be stored in the display case and packed away for easy storage.



FOLDING DISPLAY PANELS



WEIGHS
5 LBS **VY 1**

Voyager Mini kit (small)
open dimensions: 48" w x 18" h
closed dimensions: 24" w x 18" h



WEIGHS
6.5 LBS **VY 2**

Voyager Maxi kit (medium)
open dimensions: 48" w x 24" h
closed dimensions: 24" w x 24" h

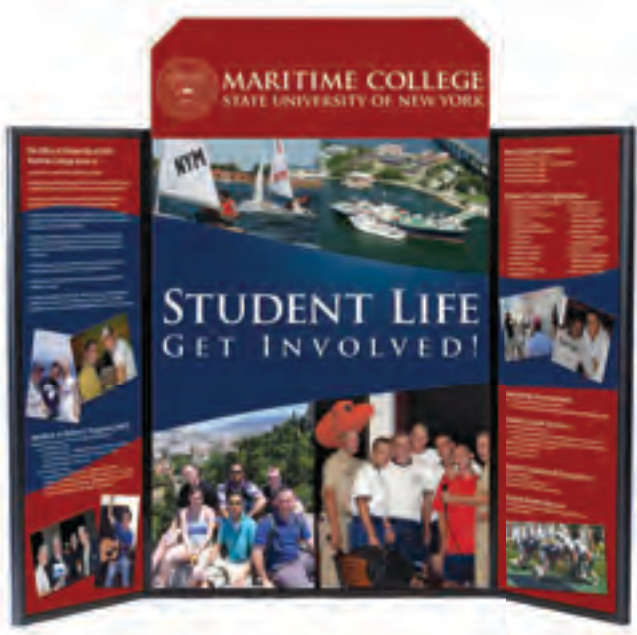

WEIGHS
8.25 LBS **VY 3**

Voyager Mega kit (large)
open dimensions: 48" w x 32" h
closed dimensions: 24" w x 32" h



WEIGHS
8.25 LBS **VY 4**

Voyager Supreme kit (x-large)
open dimensions: 64" w x 24" h
closed dimensions: 32" w x 24" h



**WEIGHS
TO LBS** VY 5

Voyager Monster kit (xx-large)
open dimensions: 64" w x 32" h
closed dimensions: 32" w x 32" h



VOYAGER CARRY BAG



- Voyager Mini bag: VY-1-BG
- Voyager Maxi bag: VY-2-BG
- Voyager Mega bag: VY-3-BG
- Voyager Supreme bag: VY-4-BG
- Voyager Monster bag: VY-5-BG



CUSTOMIZE

Brand the exterior of your Voyager to match your company and/or product colors to maximize your marketing efforts. Minimum 12 units, call for details.





HORIZON™ DISPLAY PANELS

- main panel sizes approximately = 24" w x 36" h
- custom sized panel displays are available
- shown with optional detachable graphics
- available in a variety of fabric color options (page 104)



WEIGHS
22 LBS
Horizon 6
HZ-6



WEIGHS
12 LBS
Horizon 3
HZ-TT-S



WEIGHS
13.5 LBS
Horizon 5
HZ-TT-M



WEIGHS
31 LBS
Horizon 8
HZ-8

TT

black & grey: TT-D-4-BK/GRY
blue & grey: TT-D-BL/GRY

- lightweight, fabric covered tabletop display
- individual panels = 18.19" w x 22.69" h
- available in 2 front & back color combinations: black/grey, blue/grey (shown with optional graphic panels)



EFEX

2801 three panel kit:
EFX-2801
2802 three panel kit w/header:
EFX-2802

- lightweight, fabric covered tabletop display
- individual panels = 28" w x 35" h
- available in a choice of 4 basic color combinations:



EFX-2801

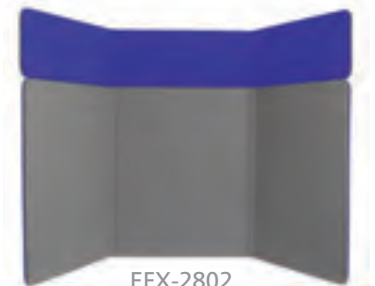

EFX-2802

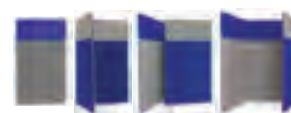



FINAL.FUNDAMENTAL.FINESSE. **ACCENTS & ACCESSORIES**

Portable counters and kiosks provide ample storage and style to complement our vast array of 8ft, 10ft and 20ft exhibit kits and displays • Accent lighting kits and solutions help stage a powerful, impactful presence that you desire • Portable transit and shipping cases are designed to protect your exhibit investment • From miniature banner stands and literature racks to poster frames and bag dispensers, a variety of display additions and accessories are at your fingertips

LINEAR™ KIOSKS

Linear™ Kiosks provide unique design elements for a custom look. Aluminum construction coupled with rigid graphic infill panels make these kiosks durable and long lasting.



each Linear kiosk comes with an OCH2 case (page 119)



LINEAR KIOSK 01
LN-K-01

- 54.4" w x 99" h x 23.25" d
- monitor mount
- fabric canopy
- approximate weight: 125 lbs



LINEAR KIOSK 02
LN-K-02

- 47.25" w x 96.85" h x 23.25" d
- monitor mount
- fabric canopy
- approximate weight: 130 lbs



LINEAR KIOSK 03
LN-K-03

- 47.33" w x 96.85" h x 23.25" d
- fabric canopy
- approximate weight: 115 lbs



LINEAR KIOSK 04
LN-K-04

- 63" w x 96.85" h x 30" d
- 50 watt spotlight
- approximate weight: 90 lbs



Linear kiosk counter tops are available in your choice of four thermoform finishes

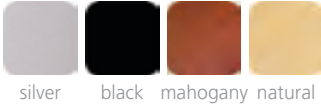

silver black mahogany natural

LINEAR™ KIOSKS

Linear™ Monitor Kiosks add function and flare to any space. Extrusion based construction coupled with your choice of rigid graphic infill panels or frosted plex panels make these kiosks sturdy and versatile.



LINEAR KIOSK 05 LN-K-05

- 25.38" w x 72.25" h x 18.5" d
- monitor mount
- approximate weight: 30 lbs



LINEAR KIOSK 06 LN-K-06

- 25.38" w x 72.25" h x 18.5" d
- monitor mount
- approximate weight: 27 lbs



LINEAR KIOSK 07 LN-K-07

- 24" w x 86" h x 21" d
- monitor mount
- approximate weight: 49 lbs



LINEAR KIOSK 08 LN-K-08

- 23.5" w x 86" h x 17.75" d
- monitor mount
- approximate weight: 46 lbs



TABLET STANDS

Are you looking to incorporate tablets into your display or environment? Sleekly-designed free standing tablet stands and kiosks make it easy to encourage interactivity, present information and engage your customers in any space.



TABLET KIOSK 01
TABLET-STD-01

- 33" w x 84.7" h x 23.73" d
- monitor mount, tablet holder
- pillowcase fabric graphic



TABLET KIOSK 02
TABLET-STD-02

- 20.2" w x 84.7" h x 23.73" d
- tablet holder
- pillowcase fabric graphic



TABLET KIOSK 03
TABLET-STD-03

- 20" w x 64" h x 15.19" d
- tablet holder
- pillowcase fabric graphic



VIBE MONITOR KIOSK
VB-MK-01

- medium monitor bracket
- max weight 50 lbs
- comes with 1 OCH2 case





TENSION FABRIC COUNTERS

Add modern flare to your trade show exhibit, event or POP display with Formulate™ and Symphony™ fabric counters. With a variety of options to choose from, mix and match to create the ideal display or reception set up.

FORMULATE™ COUNTERS

Formulate™ counters couple lightweight hardware with state-of-the-art printed stretch fabric silicone edge fabric graphics (SEG) to create funky and functional reception stands. Countertops have built in channels for LED bead lighting to create a soft glow. (LED bead lighting is an optional accessory)



PILLAR
W-01-C

HALF MOON
W-02-C

ELLIPSE
W-03-C

BULLET
W-04-C

OVAL
W-05-C

SYMPHONY™ COUNTERS

Symphony™ counters provide a unique, sleek design that lends an attractive element to any trade show or POP display. Symphony counters combine extrusion-based hardware with state-of-the-art PRINTED or COLOR stretch fabric silicone edge fabric graphics (SEG).



OVAL
SYM-OV

RECTANGLE
SYM-RCT

BULLET
SYM-BLLT

OVAL DOUBLE GRAND
SYM-OV-DBL-GRND

3 QUAD KIT
SYM-QD-3

tension fabric counter tops are available in your choice of finishes



silver black mahogany natural

counter stretch skirts are available in custom printed options as well as the following colors:



amethyst ruby sapphire emerald silver jet

LINEAR™ COUNTER

LN-TBL-SA-RCT

- coordinates with the Linear™ modular display line
- 3 graphic panels available to display your company message
- quick & easy to assemble, tool included
- fits in an OCH shipping and transport case
- aluminum design is sturdy and stable



CAMPAIGN

CP-B2

- counter dimensions not including canopy 34" w x 34.5" h x 5" d
- quick assembly
- strong & easy to clean plastic parts



HOPUP™ COUNTER

HOP-CT-S

- collapsible display counter
- very portable & lightweight
- includes black internal shelf
- hinged top available in all four laminate finishes



hinged counter top and removable internal shelf make this counter easy to pack up and store away



counter tops are available in your choice of finishes



ZEDUP 1

black: ZD-1-B
silver: ZD-1-S

- 6 pocket rack
- can be stored or shipped loaded with literature



hard case upgrade:
black: ZD-1HC-B
silver: ZD-1HC-S



ZEDUP LITE

silver: ZD-LITE

- 6 pocket rack
- collapsible
- lightweight version of the ZedUp
- constructed from aluminum & plastic for reduced weight



INNOVATE

black: INN-B
silver: INN-S

- modular design
- 10 pockets
- packs in 3 separate parts for reduced shipping size



TITAN

black: TITN-B

- modular design
- heavy duty
- 8 pocket
- packs in 3 separate parts for reduced shipping size
- carry bag sold separately



ILLUSION

black: IL-1-B
silver: IL-1-S

- fast-folding cantilever rack
- 4 front facing pockets



VICTORY

black: VIC-B
silver: VIC-S

- slim, modular, snap-together design



10 UP

black: 10UP-B

- strong & stable
- 10 pockets
- packs flat

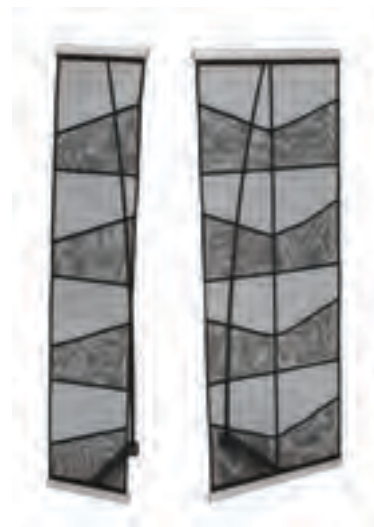

LR 1 & LR 2

4 pocket: LR-1
8 pocket: LR-2



- modular, roll-up mesh design
- holds standard 8.5" w x 11" h literature
- 4 or 8 pocket model
- black with chrome accent



All literature racks come with a five year warranty, a carry bag, and are a eco-friendly choice.

DISPLAY ADDITIONS



From miniature retractable banner stands to poster frames, towers, bag dispensers and more. Display accessories and accents are designed to help add the final touches, function and flare to any display or space.

BREEZE

BREZ-1-S: 8.375" w x 13" h
BREZ-2-S: 11" w x 17" h



- retractable tabletop stand
- ideal for custom calendars & other promotional banners

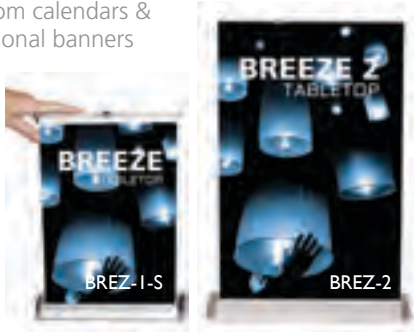

L-MINI

L-MINI



- standard height = 26.875" h
- tabletop tension banner stand
- adhesive rail
- anodized silver finish



APEX

APEX



- double-sided plastic a-frame
- can be printed directly on the plastic for a smooth look
- for indoor or outdoor use



SYNERGY

SYN-2-1



- double-sided aluminum a-frame
- snap edges for quick graphic changes
- silver anodized finish



WEDGE

WED-1-B

- combine multiple units for longer and taller displays
- graphic size is variable
- black only
- graphics not included

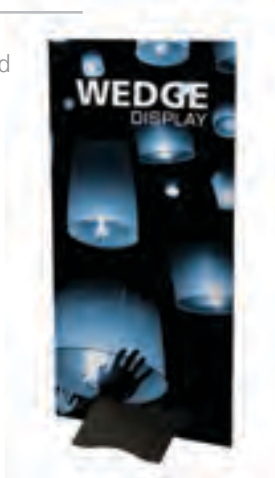

OASIS

OASIS

- highly portable
- three arm collapsible bag dispenser
- shiny silver finish



STEP STOOL

STEP STOOL-BLUE



- sturdy EZ FOLDZ step stool
- 300 lb capacity
- folds flat for storage & transport
- blue only





DISPLAY ADDITIONS

From miniature retractable banner stands to poster frames, towers, bag dispensers and more. Display accessories and accents are designed to help add the final touches, function and flare to any display or space.

POSTER SNAPPER

- adjustable hanging clips slide along the top rail to match desired spacing
- hanging clips feature both top opening for clear nylon line mount, and recessed pocket for S-hook suspension
- rails snap open and shut for quick graphic changes
- clean, simple, elegant look
- comes in 4 different standard widths: 24", 30", 36", 48"
- custom cut width available up to 60"



TRAPPA POSTER FRAME

- black or silver anodized finish w/precision mitered corners
- spring loaded aluminum extrusions mounted to a high-impact polystyrene backer
- trappa frame edges snap open from the front to allow quick and easy graphic changes with no tools required
- available in a wide range of standard sizes & includes a clear anti-glare lens



BACKLIT TOWER

- collapsible double-sided free-standing towers, just add the optional lighting kit and turn your tower into a free-standing lightbox!
- 24" or 33" wide x 72" tall "bubble" panels for maximum visibility
- recommended printing material: .040"-.125"
- your choice of silver or black aluminum edge extrusions
- black thermoformed laminate top & bottom plates



DISPLAY ADDITIONS

From miniature retractable banner stands to poster frames, towers, bag dispensers and more. Display accessories and accents are designed to help add the final touches, function and flare to any display or space.



OBSERVE DELUXE OBS-DLX

NEW

- stylish double-sided curved design
- holds two 24" w x 36" h bubble graphics
- recommended printing material: .040"-.125"
- elegant brushed silver
- sturdy steel base with removable and adjustable brochure pockets



OBSERVE GRAND OBG-B

- sleek info center includes sturdy base & adjustable shelf
- accepts 22" w x 28" h graphic size
- single or double sided
- holds a 3/16" thick mounted graphic



OBSERVE PRO OBS-LP-SYS

- lightweight snap together info center
- 12" diameter base
- stylish curved header
- adjustable brochure holder
- accepts 8.5" w x 11" h graphic and literature
- molded sign clamp will hold an 1/8" thick mounted graphic





CASES & CRATES

It's critical to protect your tradeshow exhibit investment with a quality constructed transit and shipping case. An extensive selection of exhibit and display cases and crates to choose from that are all made in the USA and are designed to house specific lines of exhibits and displays for maximum portability and protection during shipping.

OCA2

OCA2

- attaches to the OCFM or OCHM
- ideal for lights and accessories
- secure straps help to assure case will remain closed during transport
- interior size:
32.75"l x 13.5"w x 4.25"h
- exterior size:
34"l x 15"w x 7"h
- weight when empty: 8 lbs



OCS AND OCL

small: OCS
large: OCL

- secure reinforced straps help to assure case will remain closed during transport

OCL

- interior size:
13.5"l x 13.5"w x 50"h
- exterior size:
19"l x 19"w x 56"h
- weight when empty: 20 lbs

OCS

- interior size:
13.5"l x 13.5"w x 39.5"h
- exterior size:
19"l x 19"w x 45"h
- weight when empty: 18 lbs



OCB

OCB

- this expandable shipping case fits up to three swivel-foot banner stands with bags or one premium stand with bag*
- also used for Formulate™ lite displays
- interior size min/max:
min - 28.38"l x 12"w x 3.38"h
max - 44.25"l x 12"w x 3.38"h
- exterior size min/max:
min - 31"l x 17"w x 7"h
max - 47"l x 17"w x 7"h
- weight when empty: 9 lbs
- *case does not fit Orchid, Dash, Uno, Spring 5, Contender 48 or banners over 39.37" wide



OCE

OCE



- the perfect protective shipping and/or storage case for all Formulate™ exhibit kits, hanging structures and accessory products
- adjustable roto-molded expandable display case
- adjustable lid and easy pin latch
- interior size min/max:
min - 14"l x 11"w x 38"h
max - 14"l x 11"w x 65"h
- exterior size min/max:
min - 17"l x 18"w x 39"h
max - 17"l x 18"w x 65.25"h
- weight when empty: 21 lbs
- separate fabric graphic converts the case into a counter



OCP
OCP

- light storage in the lid
- premium latches for maximum strength
- interior size:
35"l x 21.5"w x 12.25"h
- exterior size:
40"l x 27"w x 18"h
- weight when empty: 21 lbs



OCP2
OCP2

NEW

- premium latches for maximum strength
- hinged lid with internal light storage
- robust, roto-molded plastic
- interior size:
35"l x 14"w x 22.5"h
- exterior size:
40.5"l x 18"w x 26"h
- approximate weight when empty: 32 lbs



OCP ELITE
OCP-ELITE

- lid can be used as a step stool while assembling displays
- access door provides storage when unit is used as a counter
- interior size:
35"l x 21"w x 14.25"h
- exterior size:
39"l x 27"w x 18"h
- weight when empty: 31 lbs



OC-HOP
OC-HOP

- ideal for Hopup backwall displays (fits up to 3x3 hopup)
- built-in handle and wheels for easy transport
- interior size: 34"l x 14"w x 14"h
- exterior size: 36"l x 18"w x 18"h
- weight when empty: 17 lbs



OCH
OCH

- roto-molded case for exhibits, graphics & accessories
- secure reinforced straps help to assure case will remain closed during transport
- strong yet lightweight
- interior size:
47.25"l x 23.75"w x 8"h
- exterior size:
50"l x 29"w x 12"h
- weight when empty: 22 lbs



OCH2
OCH2

- heavy-duty shipping and storage case
- ideal for Linear hybrid displays
- secure reinforced straps help to assure case will remain closed during transport
- interior size:
48.25"l 24"w x 14"h
- exterior size:
52"l x 30"w x 15"h
- weight when empty: 30 lbs



OCHM
OCHM

- interlocking surface to enable two cases to be transported together
- maximum case depth = 8" allowing up to 8 flat panels per case
- interior size: 36.5"l x 23.75"w x 9"h
- exterior size: 38"l x 28"w x 13"h
- weight when empty: 20 lbs



OCFM
OCFM

- interlocking surface to enable two cases to be transported together
- maximum case depth= 8" allowing up to 8 flat panels per case
- interior size: 47.25"l x 35.75"w x 9.5"h
- exterior size: 49"l x 39"w x 15"h
- weight when empty: 35 lbs



OCF
OCF

- offers the same features and benefits of the OCT in a rectangular shape
- interior size: 47.25"l x 35.75"w x 18"h
- exterior size: 51"l x 38"w x 24"h
- weight when empty: 55 lbs



OCF2
OCF2

- molded stackable shipping crate 18" deep
- heavy-duty roller bearing recessed in bridge of case
- holds 18 layers of flat panels in horizontal direction
- interior size: 47.25"l x 47.25"w x 18"h
- exterior size: 51"l x 51"w x 24"h
- weight when empty: 70 lbs



OCM
OCM

- black LDPE case designed for LCD monitors
- built in dry erase board to label contents and location
- fits 37" - 47" screens
- includes 3" casters with rubber wheels
- must be shipped freight
- interior size: 45.5"l x 5"w x 30"h
- exterior size: 54"l x 16"w x 35"h
- weight when empty: 55 lbs



OCT
OCT

- designed to handle national & international exhibit freight shipments
- offers maximum protection for your exhibit materials
- interior size: 47.5"l x 44.25"w x 34.5"h
- exterior size: 50"l x 47"w x 43"h
- weight when empty: 138 lbs



All cases come with a one year warranty, are an economic & eco-friendly choice, & made in the USA.

LUMINOSITY™ DISPLAY LIGHTING



Lighting can create a powerful, impactful presence or display. Illumination is an important piece of the puzzle to achieve the mood, style and staging that you desire. A variety of Luminosity™ display lights, lighting kits and solutions to help clients make their projects shine!



LUMINA 1

black: LUM-1-B
chrome: LUM-1-C

- low voltage 50 watt spotlight & universal fittings kit
- "goose neck" arm
- mounts horizontally
- LED option available

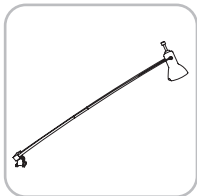

LUMINA 2

LUM-2-1

- low voltage 50 watt slender spotlight
- mounts to a vertical pole
- brushed stainless steel finish
- LED option available

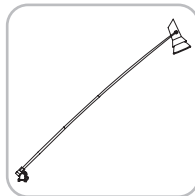

LUMINA 3

LUM-3

- low voltage 50 watt
- spotlight, chrome with a black head & universal fittings kit
- telescopic arm
- extends from 7"-22" long
- LED option available

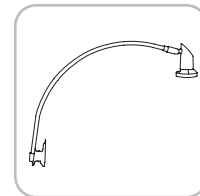

LUMINA 5

LUM-5

- low voltage 50 watt spotlight & universal fittings kit
- deluxe chrome head
- telescopic arm
- extends from 7"- 22" long
- LED option available

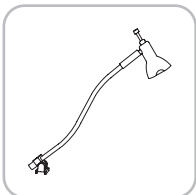

LUMINA 6

LUM-6

- low voltage, 50 watt spotlight & universal fittings kit
- stylish curved twin arms
- silk black only
- LED option available

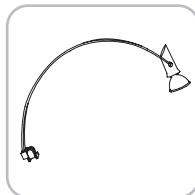

LUMINA 7

LUM-7

- incandescent 110 volt fixture
- dovetail mount
- 45 watt incandescent bulb included
- silk black only

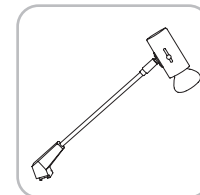



LUMINOSITY™ DISPLAY LIGHTING

Lighting can create a powerful, impactful presence or display. Illumination is an important piece of the puzzle to achieve the mood, style and staging that you desire. A variety of Luminosity™ display lights, lighting kits and solutions to help clients make their projects shine!



LUMINA 8

black: LUM-8-B
silver: LUM-8-C

- 12 volt spotlight with straight arm & adjustable head
- includes 110 volt UL approved transformer, 50 watt bulb & universal fittings kit
- 17" (431.8 mm) long from end to end
- LED option available

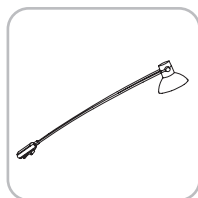

LUMINA 200

LUM-200-ORL

- 110 volt ETL approved wall washer floodlight with a straight arm & adjustable head
- light includes 120 watt halogen bulb
- 19.5" (495.3 mm) long from end to end
- silk black finish



LUMINA 200 LED

LUM-LED-ORL-B

- LED version of the Lumina 200 floodlight
- 1400 Ma, 12 VDC
- LED rated for 20,000 continuous hours

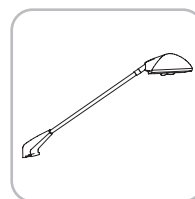

UNIVERSAL LIGHT CLAMP KIT

UNI-LT-CLP

- comes standard with the Lumina 1, 3, 4, 5, 6, 8 and allows our lights to fit a majority of banners, truss & panel kits



LUMINA SPARE BULB KIT

LUM-BULB

- (2) 50 watt low voltage spare bulbs in a padded, protective EVA formed case



LED BULB OPTION

LUM-LV-LED-BLB16

- a green solution for Lumina 1, 2, 3, 4, 5, 6, 8
- 50 watt LED bulb



SPT CASE

SPT-CASE

- EVA semi-rigid lighting case
- foam-lined padded compartments
- holds two Lumina lights & power supply



FLD CASE

FLD-CASE

- EVA semi-rigid lighting case
- foam-lined padded compartments
- stores & transports two lights
- designed for use with Lumina models 1-5

LUMINOSITY™ DISPLAY LED LIGHTING

NEW

The perfect balance of form, fabric and lighting can create a powerful, impactful presence or display. Illumination is an important piece of the puzzle to achieve the mood, style and staging that you desire. With Luminosity™ LED lighting kits and solutions, we can tailor the ideal lighting system to make your project glow!

LED STRIP LIGHTS ARE IDEAL TO ILLUMINATE ANY 10FT BY 20FT FLIP™ DISPLAY



LED STRIP LIGHTS – WARM WHITE

LED-WHT-STRIP

Includes 1 power supply, 1 meter length strip of lights

LED-WHT-STRIP-K

Includes 1 power supply, 4 - 1 meter length strip of lights with connectors

- 12V high lumen warm white 3,000K LED Strip lights
- projects warm light outputs
- strips come in 1 meter (39.4") lengths
- includes wire connectors to one side of strip and adhesive backing
- connectable up to 4 meters of lights on one power supply
- UL approved



LED STRIP LIGHTS – RGB

LED-RGB-STRIP

Includes 1 power supply, 1 meter length strip of lights, 1 RGB transponder and 1 remote control

LED-RGB-STRIP-K

Includes 1 power supply, 4 - 1 meter length strip of lights with connectors, 1 RGB transponder and 1 remote control

- 12V high lumen RGB 3,000K LED Strip lights
- projects any color in the RGB spectrum
- strips come in 1 meter (39.4") lengths
- remote control operated RGB allows for light output control
- includes wire connectors to one side of strip and adhesive backing
- connectable up to 4 meters of lights on one power supply
- UL approved

ILLUMINATE FORMULATE™ COUNTERS AND SYMPHONY COUNTERS



LED BEAD LIGHTS – WARM WHITE

LED-WHT-BEAD

Includes 1 power supply, 1 meter length strip of bead lights

*Note – strips cannot be linked together

- 96 LED 4-5LM/LED 12V warm white 3,000K
- projects warm light outputs
- strips come in 1 meter (39.4") lengths; lights cannot be linked
- includes wire connectors to one side of strip and rubberized texture for push-in applications
- UL approved



LED BEAD LIGHTS – RGB

LED-RGB-BEAD

Includes 1 power supply, 1 meter length light strip, 1 RGB transponder and 1 remote control

*Note – strips cannot be linked together

- 96 LED 4-5LM/LED 12V RGB 3,000K
- projects RGB light output
- strips come in 1 meter (39.4") lengths; lights cannot be linked
- includes wire connectors to one side of strip and rubberized texture for push-in applications
- UL approved

ILLUMINATE FORMULATE™ FUNNELS, CYLINDERS, TOWERS AND MORE

COLOR BLAST ACCENT LIGHTS



LED-WRM-WHT-BLAST
Features a warm white LED light output; good for light-colored and neutral graphic prints. 3,000K



LED-COOL-WHT-BLAST
Features a cool LED light output; good for darker graphic prints. 6,000K



LED-RGB-BLAST
Features multi-pattern flashing RGB LED light output; RGB spectrum cannot be controlled.

- 85-265 voltage, 13 watt LED blast light
- projects your choice of warm or cool WHITE, and a RGB spectrum flashing pattern
- 7" round x 7" h (when faceplate is flush with base and not angled)
- angels to 60°
- UL approved

LED FLOOD LIGHT



LED-FLOOD
- 85-265 voltage, 42 watt LED Flood light (equivalent to 400 watt halogen)
- projects cool WHITE light
- 7.4" w x 9.44" l x 5.11" d
- angels to 120°
- UL approved

wayfinding signage solutions available at:

www.SIGNMAKERS-HANDBOOK.com

featuring a wide range of configurations for a consistent look throughout your building

INFO CENTERS

TRIANGULAR SIGNS

DESK FRAMES

SUSPENDED SIGNS

FREE STANDING PYLONS

WALL-FRAMES

PROJECTING SIGNS

DIRECTORIES



user-friendly, versatile, affordable solutions | front-loading design for easy graphic change

CONTACT US FOR OPTIONS, SPECS & DIMENSIONS

AMERICA'S
FAVORITE
TRADESHOW SUPPLIER

BROUGHT TO YOU BY:

www.exhibitors-handbook.com

